

## A. BTA-REQUIRED BICYCLE PLAN ELEMENTS

Caltrans requires that bicycle plans include certain components, as identified in Section 891.2 of the California Streets and Highway Code, to be eligible for state Bicycle Transportation Account (BTA) funding. Table A.1 summarizes these elements and the chapters of this plan in which each is addressed.

**TABLE A-1. CALTRANS BICYCLE TRANSPORTATION ACCOUNT FUNDING REQUIREMENTS**

Element	Chapter of this Plan
Number of Existing and Future Bicycle Commuters	Appendix D
Land Use and Settlement Patterns	Chapter 3
Existing and Proposed Bikeways	Chapters 3 (Existing) and 5 (Proposed)
Existing and Proposed Bicycle Parking Facilities	Chapter 3 (Existing), Chapter 5 (Proposed), Appendix I
Existing and Proposed Access to Other Transportation Modes	Chapters 3 (Existing) and 5 (Proposed)
Facilities for Changing and Storing Clothes and Equipment	Appendix I
Bicycle Safety, Education, and Enforcement Programs	Chapter 6
Citizen and Community Involvement in the Development of the Plan	Chapter 1
Coordination and Consistency with Other Plans	Chapter 2
Projects Proposed in the Plan and their Priority for Implementation	Chapter 5 (Prioritized Proposed Project List), Chapter 7 (Implementation Plan), Appendix E (Prioritization Criteria)
Past Expenditures for Bicycle Facilities and Future Financial Needs	Chapter 7

Source: Caltrans Streets and Highway Code, Section 890-894.2



## B. ACCOMMODATING A RANGE OF ACTIVE TRANSPORTATION PARTICIPANTS

The Active Transportation Plan must consider the needs of a wide range of bicyclist and pedestrian experience and skill levels. In order to serve an equally broad range of utilitarian and recreational user groups, the Albany Active Transportation Plan identifies networks for fast and slow bicyclists. Fast bicyclists typically refer to commuter and recreational road bicyclists. Slow bicyclists typically refers to “experiential” bicyclists, or those riding for pleasure or recreation. The slow bicyclist group also includes children and less experienced bicyclists. This Appendix provides more information about types of bicyclists and pedestrians.

### ***Bicyclists***

Bikeways, like streets and sidewalks, are used by a wide range of people – children cycling to school; commuters cycling to work; and others running errands, exercising, racing, or touring. Many cyclists also select their preferred facility for a given trip based on that trip’s unique features (i.e., a utilitarian ride may be “experiential” even for an expert cyclist when time allows and the option is provided). Some people are more comfortable cycling on low motorist volume streets and no motorist volume paths and some types of trips, such as hauling a trailer to the grocery store and back, are more practical on such routes. Other people prefer cycling on high motorist volume streets that offer faster travel. In order to engage the largest number of people in cycling, networks consisting of both these types of routes are needed. For this reason, two complementary cycling networks are often developed to provide for both “experiential” and “utilitarian” trips. Previous guidelines have developed specific categories of bicycle user types (American Association of State Highway and Transportation Officials (AASHTO) Guide for the Development of Bicycle Facilities):

**Experienced and Confident** bicyclists includes those comfortable riding on most types of bicycle facilities (i.e., both on-street and off-street facility types). This group also includes utilitarian and recreational riders of all ages who are comfortable enough to ride on busy roads when necessary to reach their destination; however, some may prefer to travel on lower trafficked residential streets or shared-use paths. Such bicyclists may deviate from the most direct route to travel their preferred facility type. Experienced bicycles may include commuters, long-distance road bicyclists, racers, and those who participate in regular recreational group or club rides.

**Casual and Less Confident** riders include the majority of the population, who may enjoy bicycling occasionally, but will only ride on paths or low-trafficked streets in favorable weather. These people ride for recreation, often doing so with their family, and may prefer to drive to a trailhead rather than bicycling from their house. These individuals are interested in riding more, but perceive significant barriers, particularly related to traffic safety. Some may need targeted encouragement to incorporate bicycling more regularly into their lives for shopping or commuting purposes. Others may ride on a regular basis, but do so primarily because they have no other transportation options. Over time, people in this category may move over to the ‘experienced and confident’ group.



Pedestrians are not typically grouped into specific user types; however, special consideration should be provided for several groups of persons who travel on their feet or otherwise use the pedestrian network:

**Disabled Pedestrians** include those who may be mobility-impaired, visually-impaired, or auditory-impaired. Sidewalks give access to many destinations; however, their layout and features (e.g., width, slope, stairs, ramps, furniture) can often limit use by disabled pedestrians. Intersections and crosswalks can also be challenging for these groups because of limited perception of when it is or is not safe to cross. The Americans with Disabilities Act, and the associated guidance documents, is perhaps the most significant piece of legislation addressing the needs of those with disabilities to get around their community.

**Seniors** are a vulnerable pedestrian group, because, in general, the aging process causes a deterioration of physical, cognitive, and sensory abilities that enable people to get around as quickly or safely. Many seniors remain active and busy, and often travel by foot or by public transit to work, shop, or for recreational purposes. At times, traveling on foot to the other side of a busy street can become dangerous. Problems can result from wide streets, traffic signals with insufficient crossing time, lack of convenient or safe crossing opportunities, high speed or high volume traffic, and drivers focusing their attention on other vehicles instead of pedestrians. Additionally, seniors are more likely to also have another impairment or disability that limits their mobility.

**Young children** often have trouble judging traffic and finding an acceptable gap to cross the street. The use of trained adult crossing guards has been found to be one of the most effective measures for assisting children in crossing streets safely; however, budget restraints typically restrict the number of crossing guards to only the locations nearest to a school. A variety of roadway improvements can be used to enhance the safety and mobility of children walking to or from school and other key destinations.

### ***Reasons for Walking or Bicycling***

Related to the user groups mentioned above is trip purpose, or the reason for traveling that helps identify common needs among the groups. In general, trips can be broken down into recreational (including all discretionary trips), commuter (whether to work or school) or shopping trips. The biggest difference between these groups is that while recreational walkers and cyclists may be interested in routes leading to parks or other areas of interest, commuters and shoppers are likely interested in the shortest and safest route between two points. The Active Transportation Plan identifies appropriate improvements for both recreational and commuter bicycle facilities.

### **Recreational Destinations and Needs**

Albany has a diverse recreational system that includes city parks and multi-use paths as well as access to regional parks and the waterfront that appeal to various types of bicyclists, walkers and runners. Recreational bicycling



**Image B-1:** Ohlone Greenway



includes children riding to a nearby park, casual riders riding over their lunch hour or in the evening for exercise, and older adults riding to a community center. More serious recreational cyclists often ride long distances on the weekend and may participate in organized bike tours. The common attribute of all of these activities is that they are generally done for the pleasure of the ride itself, they often have a recreational facility as a final destination, they are discretionary by nature, and they value speed and directness less than surroundings and relative safety.

Recreational bicyclists can generally be categorized into two groups. The first group is casual bicyclists who typically have short trips and often include less experienced cyclists, particularly young children and older adults. The second group includes more experienced and athletic riders who generally seek scenic back roads as their favorite domain.

These distinct types of bicyclists are important because the proposed system must provide opportunities for both groups. For the person riding for exercise, the needs are for a relatively quiet route with no stops, away from automobile traffic, if possible, preferably with visual interest and shades from the wind and sun. A loop configuration is preferred so that the rider ends up back at his/her starting point without backtracking. For the person going to another recreational destination (a park or a shopping mall), the route may consist of fairly direct back streets that allow arrival with reasonable time through a comfortable environment. For other casual riders, a route that leads through interesting neighborhoods, along creeks, or through parks and open space offers the greatest interest.

Walking or jogging is also a popular form of exercise for people of all ages. Many people who walk or run for exercise may choose to remain near their home and use the sidewalk; however, many prefer running on established paths or in parks with more absorptive surfaces, such as decomposed granite. For many recreational walkers and joggers, the choice to walk or run somewhere is based on their ability to walk or run continuously without many stops or street crossings and their perception of safety. Safety is particularly important to those who might walk or run in the morning or evening, when their path might not be as well lit, or when choosing a route, when a smooth and well-maintained route would be preferred over a sidewalk or path with cracks, uplifts or tree roots.

#### Commuter and Student Destinations and Needs

Throughout the Bay Area, most commute bicycle trips are fewer than five miles and are not regional trips, except for those commuters linking to another mode, such as at bus stops or transit stations. Continuing to allow bicycles on other modes such as AC Transit and BART and providing bike lockers at transit stations will help extend the range of commute bicyclists in Albany.

Commuter and student destinations include downtown employment centers, office parks, university campuses, and elementary, junior high, and high schools. Targeting bikeway improvements to commuters is important because most roadway congestion and a significant portion of air contaminants occur during the AM and PM peak periods.



Image B-2. Albany Bike Commuter, Bike to Work Day, May 2010



In many cases, bicycling as a commute alternative has the potential to decrease traffic volumes and in turn, improve air quality. For example, bicycle commuters in the City of Davis have reduced peak hour traffic volumes by over 15 percent – to the point that many downtown streets that would normally require four traffic lanes (with no bicycling lanes) have only two traffic lanes and ample room for bicyclists. While Davis may be an anomaly, national surveys have shown that about 20 percent of the adult population would use a bicycle to ride to work, at least occasionally, if a properly designed bikeway system existed.

Commuters and students (in the morning) travel during peak periods of traffic to destinations that may have high levels of congestion and speeds. For example, one of the most dangerous parts of a student’s commute is the drop-off zone in front of the school where many vehicles search for parking or drop-off spaces.

Commuting bicyclists have simple and obvious needs. They require bicycling lanes or wide curb lanes along arterials and collectors, loop detectors at signalized intersections that respond to bicycles, signals where school children need to cross busy arterials, periodic maintenance of the pavement, and adequate bicycle storage and lockers/showers at their destination points.

In general, commuters and students have similar travel behavior, which is typically to take the most direct route from origin to destination. For elementary school students, this may mean riding on residential or collector streets, with few crossings of major arterials. For junior high and high school students, riders may have to cross several arterials to reach school. For college students and adult commuters, rides are most often less than five miles but may be as long as 10 or 15 miles. The UC Berkeley campus, Berkeley City College and several theological schools are all within a mile south of the Albany border. In addition, several UC Berkeley-related institutions are located throughout Albany and surrounding jurisdictions.

At the most basic level, these two networks can be separated by the type of roadway and traffic volume on the bicycling route.

In Albany, the following roadways have higher traffic volumes, and might be considered potential fast routes:

- Marin Avenue
- Buchanan Street
- Brighton Avenue
- Jackson Street
- Masonic Avenue
- Key Route Boulevard
- Santa Fe Avenue
- Pierce Street

The following roadways have lower traffic volumes, and might be considered potential slow routes:

- Dartmouth Avenue
- Francis Streets
- Portland Avenue
- Washington Avenue
- Buchanan Path
- Bay Trail
- Cerrito Creek Trail
- Jackson Street
- Adams Street
- Talbot Avenue
- Ohlone Greenway
- Peralta Avenue

## C. WALKING AND BICYCLING SURVEYS

The City of Albany collected data about walking and bicycling from city residents using the surveys described in this appendix.

### **Pedestrian Survey Report**

The City of Albany conducted a Pedestrian Survey in 2007 with the purpose of identifying resident's concerns about barriers to walking and accessibility in the City. The survey was first conducted at the Solano Stroll in 2007 and at the Senior Center by the end of the same year. In addition, copies of the questionnaire are available at the library and on-line at the City's website where residents can still take the survey.

Up to date, 74 hard copies of the survey were returned and about 30 on-line surveys have been taken. The survey explored the walking habits of the individual filling out the questionnaire and those of the members of the household. The following is a summary of the hard copy survey responses.

The first section asked how many days and minutes the respondent and his or her household members walk for shopping, school, work, exercise, or other activities. According to the survey, going shopping and walking to recreational/fitness activities were the top destinations for walkers, followed by walking to school, walking to run miscellaneous errands and walking to a transit station. The distribution of walkers going shopping is mostly done between one and two days a week for most respondents and members of their households. It is interesting to note that 75% of those who walk to school do so five days a week. Thirty six percent of those walking to recreational activities indicated that they walk between one (18%) and two days (18%) a week to conduct that activity. Respondents who indicated that they or members of their household walk to a transit station do so, either one (29%) or five (29%) days a week.

The average number of minutes that takes to walk to school for 31% of the respondents is between 0-5 minutes, followed by 23% of respondents who said that it took them between 25 and 30 minutes. The Safe Routes to School effort is organizing walking school buses from the different neighborhoods to the three elementary schools. Some of these buses may take about 25 minutes to reach the school.

Twenty-nine percent of the respondents going shopping spent between 15-20 minutes walking while another 18% took between 35-30 minutes walking to reach their shopping destinations. The shopping districts in Albany are located along San Pablo and Solano Avenues. In addition, there are two main shopping attractors located in the neighboring cities: El Cerrito Plaza Shopping Center located in El Cerrito, and the East Mall located in Richmond.

Of those responding to the survey, including members of their household, 24% take transit three or more times per week. Interesting to note is that 60% of respondents including members of their households do not take transit at all. This may



indicate a higher reliance on the private automobile, proximity to their work place, or simply that transit is not convenient for them.

Thirty three percent of the respondents indicated that they or/and members of their household bike three or more days a week while 67% indicated that they did not bike.

About one percent of the respondents and members of their households use wheelchair, 3% use a walker and another 4% use a cane.

The next section explored automobile ownership and number of licensed drivers per household and vehicle parking. Roughly 44 percent of the respondents have two licensed drivers in their households, followed by 42% of the respondents whose households had only one licensed driver. Only 8% of respondents have households with no licensed drivers while 2% of respondents have more than three licensed drivers in their households. Regarding vehicle ownership, 45% of the respondents have a one-vehicle household, while 34% have two vehicles and 12% have no vehicles in their household. Twelve percent of those responding to this question had no vehicles.

The next question asked where vehicle owners (including members of the respondents' household) park their vehicle. Thirty-two percent park their vehicle on the street, 26% on their driveway and 12% in their garage.

The next question asked respondents to list and rank their major concerns about walking in their neighborhoods. The following table lists their concerns and their rankings:

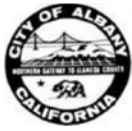
<b>Major concerns about walking in Albany</b>					
<b>1=not a concern, 5= Major concern</b>	<b>1</b>	<b>2</b>	<b>3</b>	<b>4</b>	<b>5</b>
Speeding cars/unsafe driving	13%	8%	15%	19%	44%
Missing segments of sidewalk	36%	21%	21%	4%	17%
Inadequate sidewalk	49%	26%	12%	7%	7%
Vehicles parked on sidewalks	40%	29%	14%	7%	10%
Missing/inadequate crossings	40%	35%	14%	7%	5%
Missing/inadequate curb ramps	69%	12%	10%	2%	7%
Crime	23%	27%	16%	16%	18%
Visually unappealing surroundings	41%	34%	10%	10%	5%
Lack of interesting destinations within walking distance	55%	23%	13%	8%	3%
Lack of reliable, efficient public transit	56%	15%	13%	8%	8%

The next question asked respondents to choose the reason for not walking (if they did not walk much) from a list of options. The results are the following:

I do not enjoy walking	3%
I prefer to ride a bicycle	23%
I prefer to drive a car	27%
I do not have time to walk	30%
I am physically unable to walk	17%
Total	100%

The next question asked what changed would encourage people to walk more. The results are shown in the following table:

What changes would encourage you to walk more?					
1=Much less likely, 3=No change, 5=Much more likely	1	2	3	4	5
Slower vehicle traffic	8%	5%	25%	25%	38%
More pedestrian paths	6%	9%	38%	16%	31%
Designed walking routes	6%	15%	33%	24%	21%
Maps/signs for walkers	16%	6%	31%	16%	31%
Destinations closer to home	13%	3%	43%	10%	30%
Improved street crossings	8%	6%	19%	36%	31%
Wider sidewalks	10%	10%	42%	16%	23%
More level sidewalks	6%	6%	32%	29%	26%
More attractive streets	17%	0%	40%	27%	17%
Better street lighting	9%	3%	21%	29%	38%
Better public transit	13%	17%	23%	23%	23%
Pay for parking	42%	6%	39%	6%	6%
Harder-to-find parking	37%	3%	33%	10%	17%
Improved security	13%	6%	22%	19%	41%



The following are comments stated when filling out the survey or the cards in the brochure. These comments have not been edited, just transcribed from the original source.

### *Survey Comments*

Part I: Major concerns about walking in the neighborhood. (And some specific locations)

1. Speeding cars are very dangerous.
2. Crime- Albany Bowl. BART tracks
3. I almost always feel quite safe in Albany, even at night.
4. Cars not stopping for bicycles and pedestrians at crossing, forcing me to cross only at traffic light.
5. Crime is a big issue. Pierce St. has many new incidents this year (2008). It seems crime is escalating. Ranch 99 Market parking lot area is a major concern. I don't walk to BART or EC Plaza anymore after the assault on Moser.
6. At some crosswalks particularly at Brighton Ave. and San Pablo, drivers wanting to turn right on the red light – Look to the left for on coming vehicles, but do not look right for pedestrians before turning.
7. Washington and San Pablo Avenue-difficult intersection.
8. The crosswalk in front of the senior center is particularly dangerous to cross, both morning and afternoon. There is no sidewalk on the east side of Masonic.
9. BART line is very loud – train has to slow down and get a sound wall as they have in Berkeley.
10. No traffic enforcement! Pedestrians in crosswalks are moving targets for speeding vehicles! Buchanan + Jackson – red light runners.
11. Need a crosswalk between teen center and field and bike over pass at POLK.
12. Crossing at San Pablo and main entrance of the UC village, drivers turn right without looking and almost hit me often.
13. People' landscaping blocking sidewalk. Area around Posen/Ordway/ Peralta.
14. Cars not yielding to pedestrians, especially when walking to school.
15. Ohlone path to El Cerrito BART station.
16. Drivers speed across Santa Fe constantly and despite signals, they turn regardless of pedestrians in the crosswalk.
17. Cars avoid Marin by cutting through Solano at high-speed.
18. Crashes on Castro/ San Pablo. Cars break-ins – Madison and Jackson.
19. Albany generally is not kept up with interesting landscaping as in other cities.
20. Only one ramp on most corners along Solano. Harder to manage with stroller.
21. Residential and urban intersections.
22. Why is the green light so fast crossing Buchanan at Jackson to Ocean View School? Why are our sidewalks full of weeds?
23. In the street around the El Cerrito Plaza, especially around the middle school. We see cars running stop signs almost everyday, crossing Brighton going to and from the Plaza.
24. Any Marin crossing?

25. I feel unsafe walking alone at night. There are not emergency buttons.
26. 600 Block Carmel fronts play/picnic areas in Memorial Park and is major route for circling Albany High School. Worry about kids/parents crossing street in middle of the block at same time as autos speeding from one corner to next. Speeding humps/bumps may help.
27. I like walking on Solano with my daughters and look in the windows of the shops.
28. Except at San Pablo/Buchanan and San Pablo/Marin, there is no safe pedestrian area to the city hall. No crosswalk from Madison over to city hall. No continuity of the Marin sidewalk, from the fire station connects to the side of Buchanan. It's dangerous to walk from the "point" behind the fire station, across the left turn slot. In effect, no access from Albany Hill or UC village without going to San Pablo.
29. Cars not stopping for pedestrians at crossing: San Pablo and Marin.
30. Vehicles parked on sidewalks: everywhere.
31. Make street more attractive. Wider sidewalks.
32. Many sidewalks are in bad shape. Roots of trees cause sidewalk uplifts. Uneven surface and potholes throughout the city. Not enough streetlights. Also, it's unsafe to walk on San Pablo near Albany Bowl.
33. When my daughter was younger, for a period of about two years I used to stroll her each day for 30-90 minutes to get her to nap (between Solano, Brighton, Masonic and San Pablo) I was often very annoyed at all of the (many) cars that blocked the sidewalk. I often had to go around a car, and usually there was plenty of parking on the street.

Part II: Other reasons for not walking much.

1. Crime.
2. I walk to near places.
3. I walk when I can.
4. Walking takes more than 1 hour, so driving 10-15 minutes is much faster.
5. Commuting by foot/transit isn't practical due to lack of direct route and time.
6. Lazy.
7. Working in Fremont – Commute and work take most of the time.
8. Skate boards and bicycles.
9. Police should patrol more on residential neighborhood so that we can feel safe to walk.

Part III: Other comments:

1. A bus to the waterfront, at least once in a while.
2. The surrounding areas (Ranch 99 and the street behind Ranch 99) are not safe.
3. I moved two years ago, and was really delighted by the neighborhood. It's very nice that all these places are so close. I lived in SF before and pedestrian safety is not very important there. In Albany, I find drivers yielding to pedestrians and it is excellent. And the bus is very convenient.



4. We love living in Albany because we can walk to parks, shopping, library, etc. We chose to move here because of its walkability.
5. It's great to live here, as well as to be close enough to the BART station and the Plaza. I do drive to the Plaza to shop at the markets because I have too much to carry.
6. Stop signs on Solano near school, post office, YMCA, etc.
7. Albany already does a pretty good job at being pedestrian friendly, and it's the main reason we chose to live here!
8. Bart noise! Can BART slow down to 30-35 mph in the residential areas? Instead of 60 mph.
9. My neighbors and I have noticed much more dangerous driving since Trader Joes' open. Lots of cut-through traffic, speeding, and really rude, dangerous behavior toward pedestrians trying to cross at intersections and crosswalks in North Albany. I really worry about school children being hit.
10. I like homes and storefronts on the street. I would not like to see more parking lots I would have to walk through.
11. The city is already small and many streets are already narrow. Residents drive to work because there is no convenient public transit service. Also, people from other cities drive to the city for shopping and eating, making parking more difficult.
12. Cars don't stop for pedestrians.



## ALBANY BICYCLE SURVEY

Which factors primarily dictate the route you choose for your bike ride?

- The fastest and most direct route
- The calmest streets with the least car traffic
- The most bike lanes
- The best views and scenery
- Other (please specify) \_\_\_\_\_

What is the primary reason that informs your decision to bike on a given day?

- Weather
- Ability to connect with a second mode of transportation
- Clothes you are wearing
- Bike parking at the end of the trip
- Things to carry on that trip
- Presence of bicycle facilities (such as bicycle lanes) on a direct route to your destination.

What do you think is the biggest problem with Albany's bicycle network?

- Lack of connectivity (gaps in the bike lane/path network along your route)
- Poor signage/way-finding devices directing bicyclists to major destinations
- Poor pavement conditions
- Lack of secure bicycle parking at destinations
- Bike lanes/paths are not located on the most direct route to your destination
- The bike network is wonderful. I wouldn't change a thing!

Please rate your preferred Albany cycling facilities (on a scale of 1 to 5 with 1 the best and 5 the worst):

- San Francisco Bay Trail
- Ohlone Greenway (BART Trail)
- Marin Avenue
- Buchanan Street
- Solano Avenue
- San Pablo Avenue
- Santa Fe Avenue
- Key Route Boulevard
- Masonic Avenue
- Jackson Street
- I prefer quiet residential streets

How would you rate the availability of on-street bicycle racks?

- Always there when you need them
- Never more than a block away
- Not always conveniently located
- Usually a pain to find
- Nonexistent

Which single change would do the most to make Albany a better place for bicycling?

- More bike lanes
- Better connections to and wayfinding on quiet residential streets
- More bike paths
- More secure bike parking

- Better street conditions
- Better waterfront access
- Fewer cars
- More enforcement of traffic laws

### **Tell Us a Little About Yourself**

About how many days a week do you ride your bike?

- Never
- Occasionally (less than one to two days a week)
- Frequently (about three to five times week)
- Every Day

Where does your commute typically begin? \_\_\_\_\_

Where does your commute typically end? \_\_\_\_\_

What is your age range:

Under 18  
18-35  
35-65  
Over 65

What is your gender? \_\_\_\_\_

Do you have children? \_\_\_\_\_

What type of cyclist do you consider yourself:

Beginner  
Recreational cyclist  
Advanced  
Utilitarian cyclist

Would you like to be informed of upcoming events related to the Albany *Bicycle and Pedestrian Master Plan*?

- Yes, my email address is: \_\_\_\_\_
- No thanks

Do you have any other comments about bicycling in Albany?

## D. ESTIMATING FUTURE ACTIVE TRANSPORTATION ACTIVITY

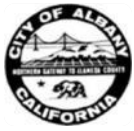
Knowing how many people walk or bicycle, and for what purposes, can help Albany develop effective projects and programs to better serve residents and resident-employees. A common term used in describing demand for active transportation facilities is “mode split.” Mode split refers to the form of transportation a person chooses to take, such as walking, bicycling, riding public transit, or driving, and is often used in evaluating commuter alternatives, where the objective is to increase the percentage of people selecting an alternative means of transportation to the single-occupant (or drive-alone) automobile. **Table D.1** presents 2000 Census data for the journey-to-work mode split for the City of Albany, compared to the United States, California, Alameda County, and the neighboring City of Berkeley. As shown, driving is the predominant means of commuting in Albany, but at a much lower share compared to county, state, and national levels and similar to its neighbor Berkeley. More people are walking to work in Berkeley, but that is likely a result of the UC Berkeley Campus being a major employer in the City.

**TABLE D.1 – EXISTING JOURNEY TO WORK**

Mode	United States	California	Alameda County	City of Berkeley	City of Albany
Drive Alone	76%	73%	67%	42%	53%
Carpool	11%	12%	11%	7%	9%
Transit	5%	5%	11%	18%	22%
Bicycle	<1%	1%	2%	8%	6%
Walk	3%	3%	4%	17%	5%
Other	5%	6%	6%	8%	5%
Total	100%	100%	100%	100%	100%

Source: US Census 2000

As shown in **Table D.1**, bicycle and walking trips represent eight percent of home-based work trips in Albany. Journey-to-work mode share is not always an accurate indicator of overall walking or bicycling activity, since commute trips only represent a portion of all trips taken by residents. Residents also take walking trips when traveling between their home and transit, or between their vehicle and transit. Additionally, the journey-to-work data does not represent the trips Albany residents take to go shopping, to school, or to social activities. This should not be misinterpreted as the non-motorized mode share of all trips for several reasons:



- Journey-to-work data only represents commute trips, which tend to be longer than shopping, school, recreation, and other trips, and are therefore less compatible with bicycling.
- Census journey-to-work data fails to capture people who commute by bicycle one or two days per week.
- Journey-to-work data does not account for commuters with multiple modes of travel to and from work, such as commuters that ride a bicycle to a BART station before transferring to transit for the remainder of their journey to work.
- No separate accounting of shopping, school, or recreational trips is made in the Census; these trips make up more than half of the person trips on a typical weekday and a significantly greater proportion on the weekend. These trips also tend to be short to medium in length and are therefore very well suited for bicycling.
- Journey-to-work reports information for adult work trips, but does not request data on school trips, which are much more likely to be bicycling trips because school-aged individuals cannot drive until the latter half of their high school years.

**Table D.2** summarizes non-motorized trip estimates for commute and non-commute trips. According to the Census 2000, there were 4,697 enrolled students from Grade 1 to high school in Albany. The MTC estimates that approximately five percent of students walk or bicycle to school in the Bay Area; however, Albany’s non-motorized mode share is substantially higher than the Bay Area’s because of its small size and neighborhood schools. Assuming that Albany’s walk and bicycle mode share is approximately 50 percent higher than the Bay Area based on Journey to Work data (Albany has about 33 percent more walkers and bikers than Alameda County as a whole) and based on the City’s size and neighborhood schools, Albany would have about 700 student walkers or bicyclists. Approximately 1,683 of Albany workers commute by transit. BART and AC Transit estimate that approximately two percent of transit riders walk or bicycle to transit stops; assuming the same adjustments as for schools, Albany would have about 100 home-to-transit walkers and bicyclists.

**TABLE D.2 – ALBANY BICYCLISTS BY TRIP GROUP**

Trip Group	Daily Non-Motorized Commuters	
Workers (Home-to-Work Trips)	710	47%
Students (Home-to-School Trips)	700	46%
Transit Riders (Home-to-Transit Trips)	100	7%
Total	1,510	100%

Source: Census 2000; Fehr & Peers, 2010

Commute trips represent a minority of bicycle trips. To get a fuller sense of bicycling in Albany, one must account for the other reasons for which people use bicycles. The *National Bicycle & Walking Study*, published by the Federal Highway Administration

in 1995, estimated that for every commute trip made by bicycle, there were 1.74 trips made for shopping, social, and other utilitarian purposes. These types of trips can be estimated in Albany as follows:

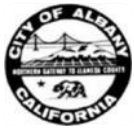
- **Number of daily bicycling commuters:** 755
- **Number of daily trips per commuter:** 2 (assuming each commuter bikes to work or school and then bikes home again later)
- **Number of daily bicycling commute trips:** 1,510 (755 x 2)
- **Daily bicycle trips for non-commute purposes:** 2,627 (1,510 x 1.74)

Lastly, bicycling is a popular recreational activity for all age groups. While most of this Plan is focused on encouraging bicycling as a form of transportation, recreational riders, with encouragement, may transition to bicycling commuters. Similarly, recreational bicycling can be a popular family activity, and children who ride with parents may be more likely to bicycle to school or with their friends. Regardless, Albany has a mild climate; flat terrain; access to regional trails such as the Ohlone Greenway and Bay Trail, and proximity to popular road bicycling routes such as Tilden Park.

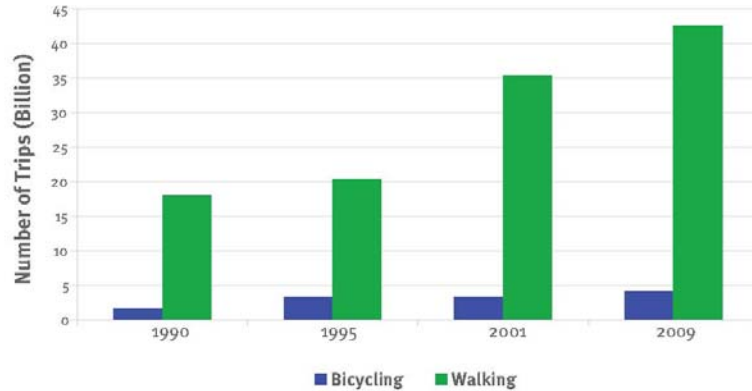
The Federal Highway Administration and U.S. Department of Transportation released in May 2010 the *National Bicycle & Walking Study: 15 Year Status Report*. The agencies found that between the initial report in 1995 and household survey data collected in 2009, bicycling activity had increased in general, though not to the goal of doubling walking and biking trips that was set in 1995. Only one percent of respondents in the 2009 National Households Transportation Survey said that they made everyday trips by bicycle, 12 percent said that they had ridden a bicycle in the past week.

#### Future Non-Motorized Activity

Future walking and bicycling trips will depend on a number of factors such as the availability of well-connected facilities, appropriate education and promotion programs designed to encourage walking and bicycling, and location, density, and type of future land development. Cities with thoughtful bikeway and pedestrian plans and meaningful implementation programs have found high levels of correlation between bicycling facilities and number of bicyclists. Three cities with such plans – Portland, San Francisco, and Seattle – found that the number of bicyclists on a bicycle corridor after it was improved was double or triple the before count. The City of Davis, California, which has aggressively implemented bicycling infrastructure, has a bicycle-to-work mode share of 16 percent. More generally, the 2010 *National Bicycle & Walking Study: 15 Year Status Report* found that between 1990 and 2008 funding for bicycling and walking projects increased from less than 0.5 percent of federal transportation funding to about one percent. Over that same time, pedestrian and bicycle trips increased by about 50 percent.



### Number of Trips Taken by Bicycling and Walking, 1990–2009



### Federal Pedestrian and Bicycle Funding, 1992–2009



Source: National Bicycle & Walking Study: 15 Year Status Report (2010)

With appropriate bicycling and walking facilities in place and implementation of employer trip reduction programs, the number of people walking or biking to work, school, or to shop could increase above its current rate. By implementing the recommendations in this plan, Albany could potentially double the number of daily trips done on foot or on bicycle, especially if this plan’s goals, policies and recommendations are directed at people who would most likely switch to walking or biking, including workers who work within five miles of Albany, school children, and transit riders. However, as implied earlier, projecting and estimating how many people walk or bicycle is difficult, at best, especially without a citywide bicycle and pedestrian count program or a citywide household travel survey. If Albany can achieve success similar to other Cities and national goals, as shown in **Table D.3**, the walk and bicycle travel mode shares could increase dramatically and be a significant segment – up to 22 percent – of all trips taken.

**TABLE D.3 – ALBANY TRAVEL MODE SHARES – EXISTING AND 2020**

Mode	City of Albany – Today	City of Albany – 2020
Drive	62%	52%
Transit	22%	20%
Bicycle	6%	12%
Walk	5%	10%
Other	5%	6%
Total	100%	100%

Source: Fehr & Peers, 2010

## E. PRIORITIZATION

### PRIORITIZATION

Although all of the projects identified in this Plan, including basic signing and striping projects, would improve bicycling and walking in Albany, some would have a more substantial impact, serve more residents, or be easier to fund than other projects. The Projects discussed in Chapter 5 were prioritized using a methodology developed specifically for the City of Albany, but similar to methods used by other East Bay and Bay Area agencies. Each project was assessed on a point system on the five elements:

**Activity Centers (0 to 3 points):** The number of local and regional activity centers on or near a proposed project. Activity centers include existing or planned parks and recreation centers, shopping and medical centers, schools, and large employment centers. Examples of activity centers in Albany are the Library/Community Center, Target Shopping Complex, Albany Waterfront, Solano Avenue Commercial Corridor, San Pablo Avenue Commercial Corridor, and Albany Hill Park. The total number of activity centers along a bicycling route was averaged on a per-mile basis.

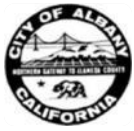
**Safety (0 to 6 points):** The methodology for assessing the safety of projects is based on the number of collisions on the roadway over the past five years and/or through assessments based on walking/bicycling audits. The methodology for assessing the safety of off-street paths is based on the potential for conflicts with motor vehicles.

**Connectivity (0 to 7 points):** This criterion evaluates the ability of a project to provide access to major streets, to provide connections between activity centers, and to connect to and extend existing bicycling facilities and to link neighborhoods and/or overcome physical barriers between them. Projects with high connectivity received seven points, moderate connectivity received two points, and low connectivity received one point.

**Regional Access (0 to 3 points):** Projects were evaluated on their ability to improve connections to regional trails or neighboring jurisdiction bicycling networks.

**Relative Ease of Implementation (0 to 3 points):** The relative ease of project implementation was determined through a review of existing plans, field review of the study area, and level of construction required for implementation.

The following ranking of projects provides an initial framework for the relative priority of projects. As community needs and interests change over time, new development opportunities arise, and as facilities on the citywide networks are completed, priority projects will also shift. The City should reevaluate the prioritization scoring on an ongoing basis to ensure that the list reflects current values and real time opportunities.



Project	Activity Centers	Safety	Connectivity	Regional Access	Implementation	Overall Score	TAC Rank
Jackson Street Safe Routes to School	2	3	8	2	3	21	2
Adams Street Bicycle Route	3	3	7	2	2	20	1
Masonic Avenue Bike Route	3	5	7	2	2	19	16
Talbot Bike Route	3	5	6	2	2	19	9
Solano Avenue Streetscape, Greening & Pedestrian Safety Project	3	5	4	2	3	18	5
Kains Avenue Bicycle Route	3	5	3	1	2	17	2
Ohlone Greenway Crossings	3	5	2	3	3	17	9
San Pablo Streetscape and Pedestrian Safety	3	5	3	2	3	17	9
Marin Avenue Pedestrian and Bicycle Enhancements	2	4	5	1	3	16	5
Eastshore Frontage Road Path	2	2	6	0	2	15	2
Dartmouth Bike Route	2	3	7	1	1	15	5
Cerrito Creek Path	2	3	7	0	2	15	9
Santa Fe Bike Route	1	3	6	2	2	15	9
Washington Avenue Bike Boulevard	3	4	5	0	2	15	5
Key Route Boulevard Median Path	2	4	4	2	2	14	16
Polk Street / UC Village Connection	2	2	3	1	2	11	9
Peralta Bike Route	1	2	4	2	1	10	21
Portland Avenue Safe Routes to School	1	2	4	0	2	10	9
Francis Street Bike Route	1	2	4	0	2	9	16



## F. PEDESTRIAN DESIGN GUIDELINES<sup>1</sup>

This section outlines guidelines for the design of walking facilities in the City of Albany. Safe, walkable streets are a vital aspect of City life and enhance the health of our communities. Well designed walking spaces should be comfortable for all residents – young and old – to enjoy.

### WHAT IS THE PEDESTRIAN REALM?

The pedestrian realm consists of walkways, pedestrian crossings, and open spaces. Walkways are “prepared exterior routes, designed to provide walking accessibility. Walkways are general walking routes, including plazas and courts, and sidewalks are walkways that parallel a vehicular roadway.”<sup>2</sup> Additionally, pedestrian crossings, where pedestrians traverse a roadway, are considered part of the pedestrian realm. Plazas and courts are locations, either publicly or privately-owned, accessible to pedestrians.

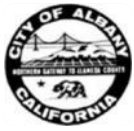
The quality of the pedestrian realm has two components: accessibility and comfort. The City of Albany seeks to maximize both elements for all users. There are three elements addressed in these guidelines:

1. *Curb or corner zone* – the area closest to the street where items such as street furniture, utility poles, and newspaper racks are usually located.
2. *Travel zone* – generally considered to be the sidewalk and crosswalk, as well as special walking-only areas such as plazas and courts. Multi-use trails and open space may also be considered travel zones.
3. *Buffer zone* – is the area between the street and sidewalk and is often landscaped. This zone provides distance between vehicular traffic and walking areas to create a more comfortable and safe environment for pedestrians.

---

<sup>1</sup> The final design of the improvements at specific locations must be left to the professional engineer who will be responsible for the design and who will be charged with exercising good engineering judgment that meets acceptable standard of care for pedestrian, bicycle and vehicular traffic.

<sup>2</sup> U.S. Department of Transportation



## CURB ZONE

Good curbs and corners have several basic attributes. They should be:

- Clear of obstructions: They have enough space to accommodate the typical number of pedestrians waiting to cross.
- Visible: Pedestrians waiting to cross the street should have an unobstructed view of approaching vehicles and approaching motorists should be able to see waiting pedestrians easily.
- Intuitive: Symbols, marks, and signs used at corners should be universal and clear so that both motorists and pedestrians know what actions or movements to make and expect.
- Accessible: Everything at the corner, including ramps, landings, call buttons, signs, symbols, marks, and textures, must meet standards dictated by the Access Board, as required by the Americans with Disabilities Act.
- Discreet: Corners should be separate from vehicle traffic. They should have design features that disallow vehicles from encroaching.

The primary guidelines governing corners are included in the Americans with Disabilities Act (ADA). The ADA is a civil rights act, signed into law in 1990, which prohibits public agencies from discriminating against individuals with disabilities. All new curb ramps in Albany must comply with the Americans with Disabilities Act Accessibility Guidelines (ADAAG) and the State of California Code of Regulations Title 24. The California Disabled Accessibility Guidebook (CalDAG) synthesizes the recommendations from both sources.

### Curb Ramps

The ADA defines two types of curb ramp systems, “Perpendicular Ramps” and “Parallel Ramps.”

Every ramp must have:

- A landing at the top and at the bottom
- A maximum ramp slope in the right-of-way of 1:12
- A cross slope of no more than 1:50
- A minimum width of 915 mm (3'-0")
- A landing at the top least 1,220 mm (4'-0") long and at least the same width as the ramp itself

- A slope no more than 1:50 in any direction

If the ramp runs directly into a crosswalk, the landing at the bottom will be in the roadway. The landing, 1,220 mm (4'-0") long, should be:

- Completely contained within the crosswalk
- Have a running slope no greater than 1:20

If the ramp lands on a dropped landing within the sidewalk or corner area where someone in a wheelchair may have to change direction, the landing must:

- Be a minimum of 1,525 mm (5'-0") long
- Be at least as wide as the ramp
- Have a slope no greater than 1:50 in any direction

It is desirable to have directional ramps; ramps that point the pedestrian toward the crosswalk. For curb retrofits, this is not always feasible. It may be cost prohibitive due to utility relocation or curb reconstruction. However, **wherever possible, each crosswalk at a given corner should have a curb ramp**, similar to Figure F-2, taken from the U.S. Department of Transportation's document, *Designing Sidewalks and Trails for Access*. Dual curb ramps are especially desirable at locations with narrow sidewalks and a wide corner radius. At locations with narrow sidewalks and a tight corner radius, a single curb ramp is appropriate. Ramps and dropped landings that end directly in the roadway should have a truncated dome tactile surface.



## Pedestrian Area at Corners

The pedestrian area is defined as usable space for pedestrians. Corners must be functional and must accommodate those waiting to cross the street, those traveling along the sidewalk, and those who stop to congregate on the corner. The greater the number of expected pedestrians, the larger the pedestrian area should be. Other considerations sometimes erode the amount of usable space and hence the functionality of corners. Several strategies exist for expanding the pedestrian area at corners. Small corner radii generally provide the most usable space and the shortest crossing distances for pedestrians (see Figure F-3). Designers may also consider curb extensions, right-of-way acquisition, or granting public easements across private property to expand the pedestrian area.

**The pedestrian area should be clear of obstructions, especially immediately adjacent to the corner. This area is the triangle created by extending the property lines to the face of curb.** Where existing obstructions such as utility poles or newspaper racks are removed, they should not be relocated such that they obstruct a pedestrian's line of travel.

## Corner Radii

The general rule for choosing a corner radius should be to choose the smallest possible, acknowledging that each location has a unique set of factors that determine the appropriate radius. Small corner radii improve comfort, and create a more enjoyable walking environment because they create more usable space for pedestrians at the corner. They improve safety because they slow vehicle speeds and shorten the crossing distance for pedestrians and improve sightlines. Smaller corner radii are also beneficial for street sweeping operations.

While corner radii may be as small as 1'6", locations with any amount of turning traffic cannot accommodate a radius this tight. **At locations with curbside parking, a 10' radius is recommended. At locations with no parking lane, a 20' maximum is recommended.** Locations with heavy truck or transit traffic may also require a wider turning radius.

**Table F-1. Recommended Curb Radii**

Street Type	Recommended Curb Radius
Residential	15 ft
Local/Collector	20-30 ft
Arterial	30 ft
Industrial	Up to 50 ft

### Curb Extensions

Consider curb extensions at intersections of three or more lanes or at uncontrolled crossings where they may improve safety for pedestrians. Generally, **curb extensions should extend a minimum of 6' into the street adjacent to parallel parking, or 12' adjacent to diagonal parking and no further than the edge of the travel lane or bicycle lane.** The leading edge of all curb extensions should be treated with reflective material for higher visibility, unless otherwise determined by the City Engineer. Designers should exercise special care not to create conflicts between bicyclists and pedestrians and not to design the curb extension such that cyclists are forced to “take the lane” at intersections where it is not appropriate.

### Pedestrian Refuge Islands

Pedestrian refuge islands allow crossings in two stages: to medians and to the far side of the street. Refuges can be lower cost because no curb (drainage) modifications are normally required.

Pedestrian Refuge Islands should extend through the crosswalk, with a curb cut for wheelchair accessibility. Refuge islands should be clear of obstructions and have adequate drainage. They should be at least 12 feet long or the width of the crosswalk (whichever is greater) and 60 feet square. At actuated pedestrian signals, an accessible pedestrian push button should also be located in the median.

Whenever possible, especially at locations adjacent to pedestrian generators, intersections should be designed without “free rights” for vehicles. When “free rights” are necessary, pedestrian islands should be designed to maximize visibility of pedestrians and slow vehicle speeds. See the table on the right and Figure F-1 for the recommended design.

**Table F-2: Recommended Refuge Island Widths**

Speed	Minimum Width*
25-30 mph	5 feet
30-35 mph	6 feet
35-45 mph	8 feet

\*Where bikes are expected to use the crosswalk, medians should be at least six feet wide, the length of an average bike.

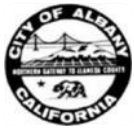
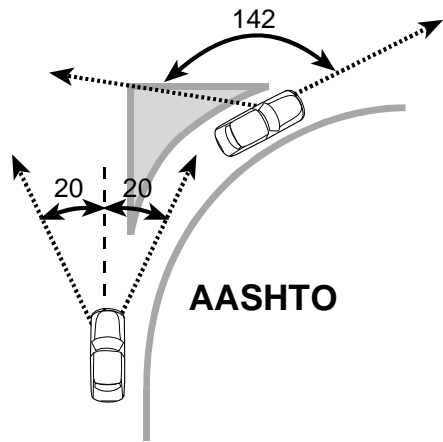


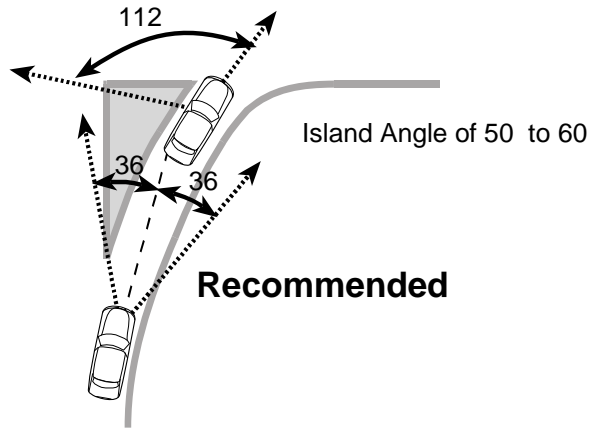
Figure F-1 Right-Turn Slip Lane Design Options

### Right-Turn Slip Lane Design Options



**AASHTO**

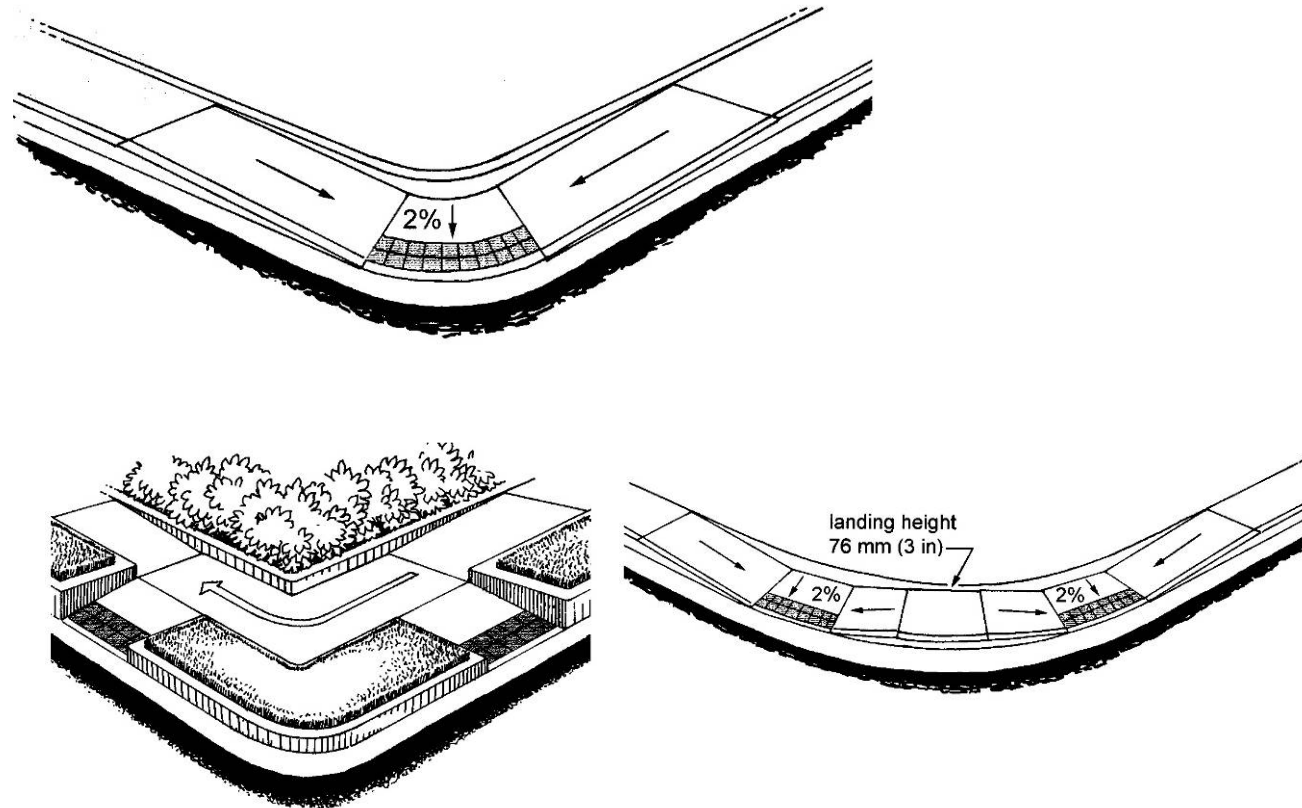
**High Speed  
Low Visibility  
Head Turner**



**Recommended**

**14 to 18 mph  
Good Visibility**

Figure F-2: Typical Single and Dual Curb Ramps<sup>3</sup>



<sup>3</sup> A corner ramp should only be considered when installation of parallel curb ramps is not feasible.

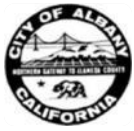
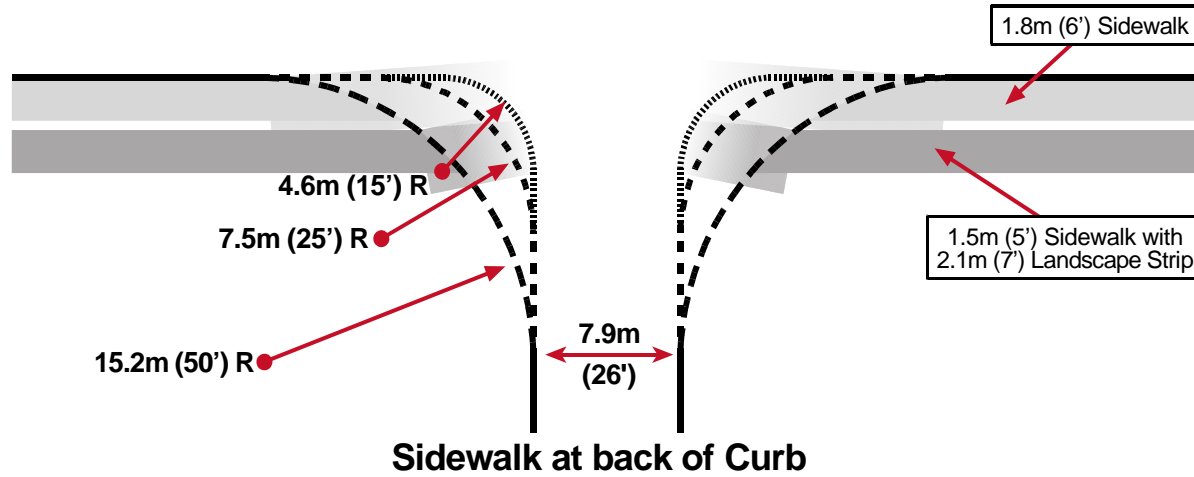


Figure F-3: Effects of Curb Radii on Crossing Distance



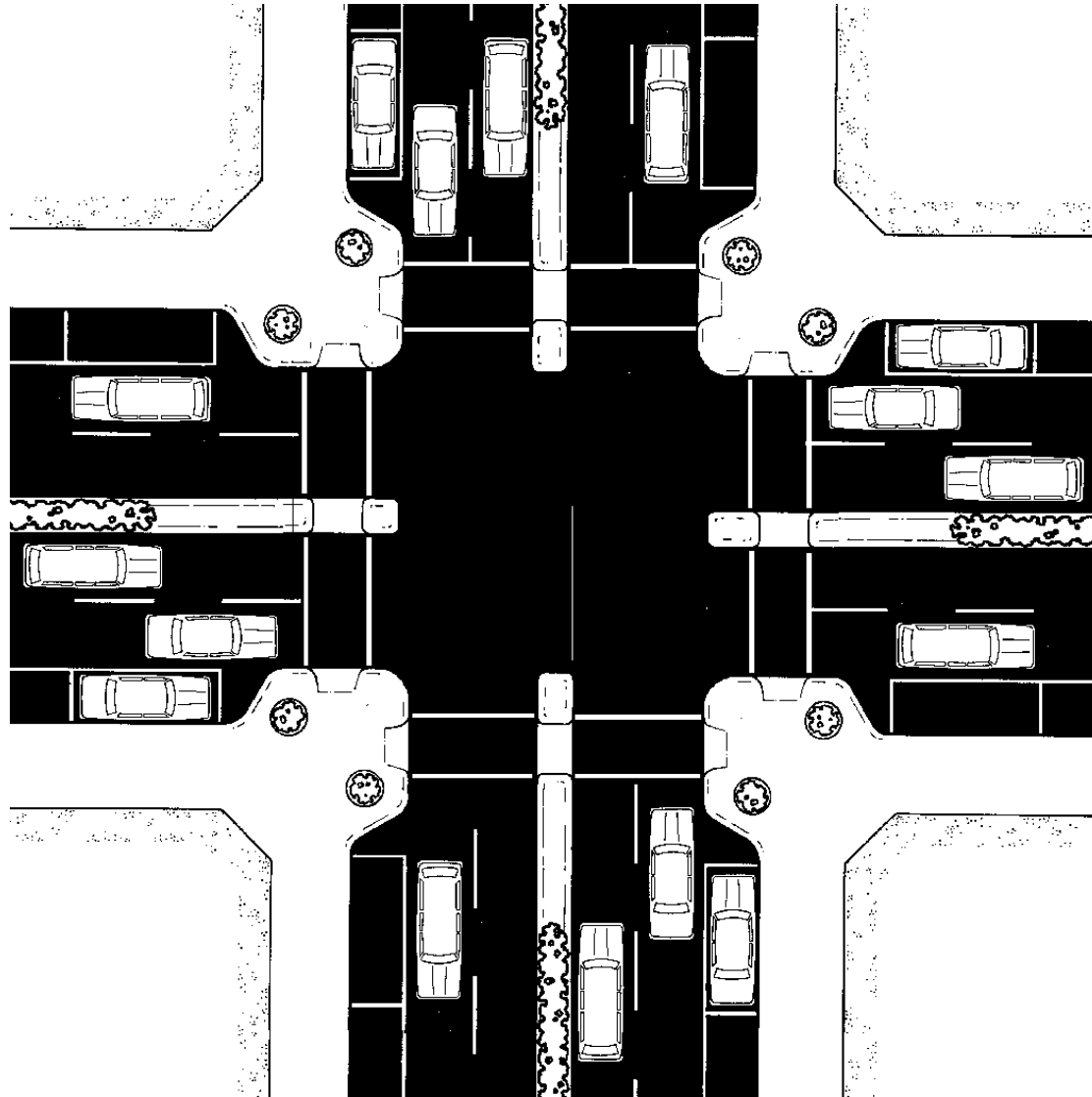
Radius	Average Vehicle Speed in Corner	Crossing Distance	Increased Crossing	Percent Increase
4.6m (15')	5 mph	7.9m (26')	+0m (0')	0%
7.5m (25')	10 mph	10.0m (36')	+3.0m (10')	38%
15.2m (50')	15mph	19.8m (65')	+11.4m (39')	150%

### Sidewalk with Nature Strip

Radius	Average Vehicle Speed in Corner	Crossing Distance	Increased Crossing	Percent Increase
4.6m (15')	5 mph	11.3m (37')	+3.3m (11')	42%
7.5m (25')	10 mph	15.2m (50')	+7.3m (24')	92%
15.2m (50')	15mph	27.1m (89')	+16.2m (53')	203%



Figure F-4 Medians and Curb Extensions Create Shorter Pedestrian Crossings



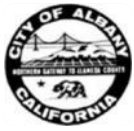
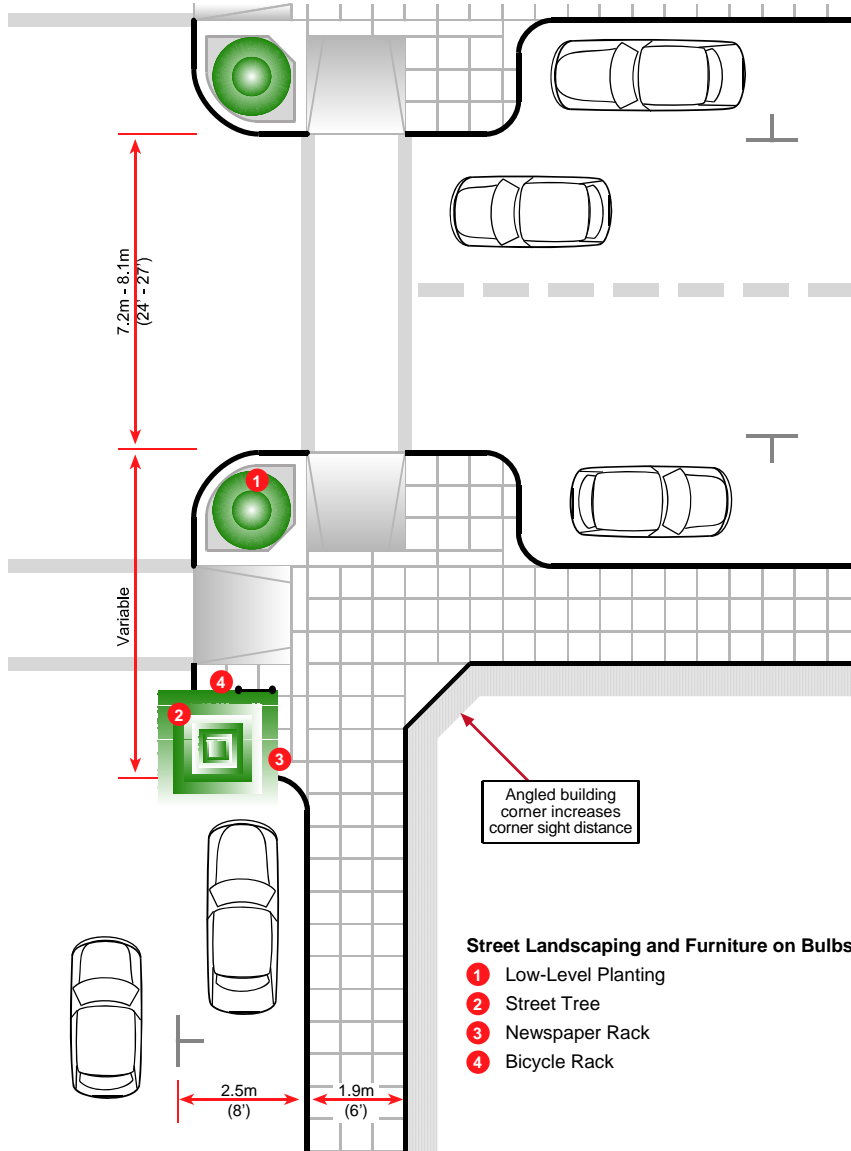


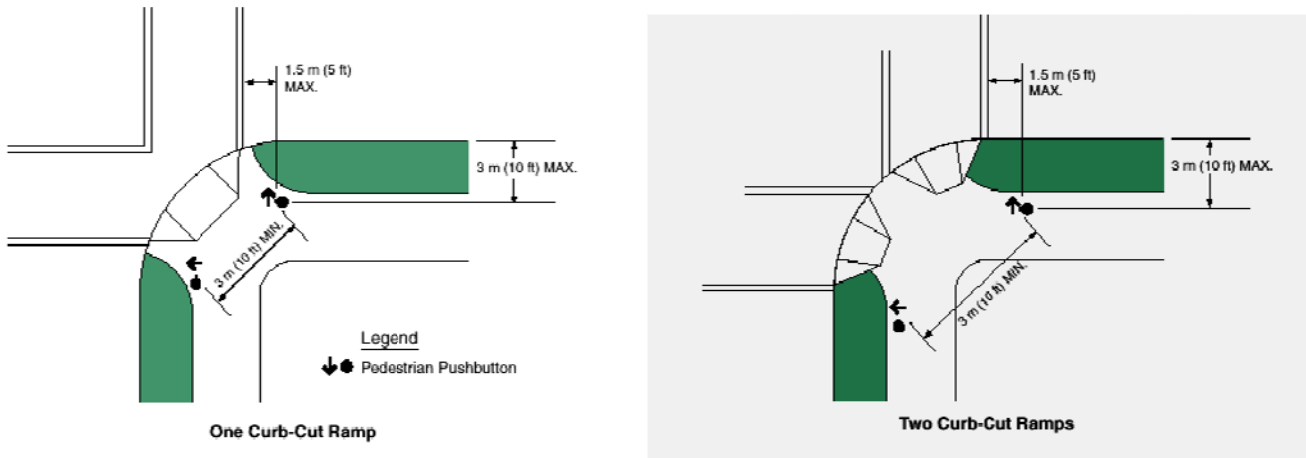
Figure F-5: Effective Use of Space at Curb Extensions near Parallel Parking

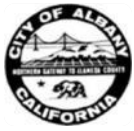


### Push Buttons

When pedestrian push buttons are used, they should be well-marked, visible, and accessible to all pedestrians from a flat surface consistent with recommendations from the U.S. Department of Transportation's *Designing Sidewalks and Trails for Access*. They should be located within five feet of the crosswalk and not further than ten feet from the curb.

Figure F-6: Pushbutton Locations for Accessible Pedestrian Signals at Dual Ramps and Single Ramps





At actuated signals where pedestrian activation is registered for greater than 75% of the peak hour signal cycles, signals should accommodate pedestrian crossings in every peak period cycle.

At locations that are not on a direct path to a generator with low side-street volumes, signals should be partially-actuated, meaning that pedestrians crossing the side streets get a WALK signal on every cycle, but pedestrians crossing the main street must use the pedestrian push button.

Where needed, pedestrian call buttons should be located to meet the following criteria:

- The closest push button to a crosswalk should call the pedestrian signal for that crosswalk.
- An arrow indicator should show which crosswalk the button will affect.
- The push button should be visible to a pedestrian facing the crosswalk, unless space constraints dictate another button placement.
- The push button must be accessible from the level landing at the top of the curb ramp, or from the dropped landing of a parallel curb ramp.
- Where audible pedestrian signals are installed, audible push-buttons should also be used. Audible signs are being installed as part of all new signals and signal modifications by several California jurisdictions due to recent settlements. Newer audible signals have the sound coming from the push button and automatically adjust to background noise. This combination addresses neighborhood concerns about the noise associated with audible signals.
- Tactile symbols may also be installed for visually-impaired persons.
- At locations where pedestrian refuge islands or medians are located and the crossing is greater than 60 feet, pedestrian push buttons should be installed in the median.



### Other Corner Zone Issues

Various elements may create obstructions in the corner zone. There are several means of reducing the number and size of the obstructions. Items such as newspaper racks, trash bins, signal boxes, and street furniture may be consolidated and, where appropriate, regulated through City ordinances. Maintaining sight distance for both pedestrians and motorists is critical, especially at intersection locations. When designing new intersections or driveway locations, it is important to measure the pedestrian's sight lines as well as those of the vehicle. Standard stopping distances from AASHTO are appropriate.

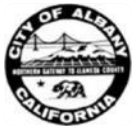
## Surfaces

Sidewalks and shared-use paths should meet the “...stable, firm, and slip-resistant...” criteria established in accessibility standards. The Access Board's “Technical Assistance Bulletin #4: Surfaces” contains additional information on the performance requirements for walking surfaces on an accessible route.

Where unit pavers are installed, it may be difficult to achieve positive drainage within the 1:48 (2%) cross slope recommended for sidewalks and shared use paths. For these surfaces, permeable or open joints may be necessary to control ponding. Some specialty pavings are not suitable for sidewalks, although they may have applications along walkways—or portions of walkways—not required to be accessible. Split-face stone units, cobblestones, and similar irregular surfaces are not easily traversed by pedestrians who have mobility impairments and may catch a dragging foot or trigger a painful spasm in response to repeated jarring in some wheelchair users. Nevertheless, some textured walking surfaces can provide useful cues to pedestrians who are blind when such materials are used as borders and edges of walkways and street crossings. Standardization and consistency in use are important for effective communication of right-of-way information. The wide range of surface textures commonly encountered on sites and public sidewalks, however, makes it difficult for blind pedestrians to derive a particular meaning from a difference in a commonly-used pattern or material. Exposed aggregate finishes have been found to be slippery when wet and are not recommended for sloping surfaces. Incised or imprinted patterns may not be detectable underfoot or to a cane. Research has shown that the truncated dome specification in ADAAG 4.29.2 is highly detectable to blind pedestrians and can be used effectively to indicate the location of a crosswalk or to indicate the division between a walkway and vehicular way, particularly where there is no distinguishable curb. Placement is critical: materials should be installed on the pedestrian walkway or curb ramp immediately adjacent to the street. (See 3.5.1 Street/Sidewalk Detectability for additional discussion).

## Street/Sidewalk Detectability

Sidewalks that ramp gradually down to a street crossing give little notice of the change from pedestrian to vehicular way for pedestrians who are blind. The blended or depressed corners and wide diagonal curb ramps popular in downtown improvement projects a decade ago were found to be difficult to detect; pedestrians with vision impairments were not able to identify the boundary between the sidewalk and the street. Raised crosswalks that continue across a street at curb height do not provide curbline cues for pedestrians with vision impairments. Narrower curb ramps with more steeply sloping side flares or returned curbing are, however, easily identified using a long cane. Research supports the need for additional cues for blind pedestrians at locations where standard indicators, such as curbs or detectable curb ramp slopes, are absent. Where ramp slopes fall below detectable limits (in California, ramp slopes of 1:15/6.67% or less), a tactile feature underfoot—such as the truncated domes of the ADAAG detectable warning specification—can provide a confirming cue, if their meaning is known. However, there has been controversy about the application of detectable warnings on exterior sloped areas. Research completed for the Access Board in 1994 did not reveal any safety problems with detectable warnings installed on walking surfaces. However, pedestrians with mobility impairments have expressed concern over their use on the slopes of curb ramps and transportation agencies anticipate problems with snow removal.



Over 30 U.S. firms currently manufacture the distinctive truncated dome surfacing that signals an approaching curblin underfoot. This tactile treatment is required at transit platform edges in the United States and is widely installed on curb ramps and at intersections in Japan, Australia, and Great Britain. Germany, France, and Belgium have begun pilot tests. An international standard is under development. Several U.S. cities have continued to install detectable warnings on new and altered curb ramps without reported problems. Engineers have suggested that the rows of flat-topped domes (less than 1/4 in/6.5 mm high) be oriented to provide a clear track for wheelchair passage over a curb ramp. Some pedestrians who are blind recommend a width of only 24 inches (610 mm)--as is required along transit platforms--for adequate detectability, which may be less objectionable to wheelchair users.

Pedestrians who have low vision will benefit from the marking of curb ramp surfaces with a contrasting color, texture, pattern, or other finish; many would choose to avoid a curb ramp, if possible. Wheelchair users have also reported the effectiveness of a contrast in curb ramp surface in identifying where an opposing curb ramp meets the street, allowing pedestrians to travel quickly and directly across the roadway to an up-ramp. Where concrete paints or stains are used, care must be taken to ensure a slip-resistant surface, particularly when wet.

Transportation industry research on color, contrast, and visibility for roadway markings has not included subjects who have low or otherwise impaired vision. Until testing can be undertaken to determine the effectiveness of standard pedestrian markings for these users, the criteria in the Manual on Uniform Traffic Control Devices (MUTCD) are a useful guide. Several states require a particular color to mark accessible features; however, there are no specific color requirements in ADAAG or UFAS.

## TRAVEL ZONE

### Sidewalks

The ADA mandates a minimum sidewalk width of four feet. Public sidewalks that are less than five feet wide require a five-by-five foot passing zone every 200 feet. This is a minimum requirement.

**On commercial streets, especially in Downtown Albany, eight feet is the desired sidewalk width.** This includes a two to three foot comfort zone on either side of the pedestrian walkway, as pedestrians generally keep about 1.5 feet clear of planters, street furniture and other obstructions near the curb. This should not prevent the City from installing wider sidewalks (up to 12 feet) in commercial districts and other locations with outdoor seating and amenities. **Sidewalks on local streets should be a minimum of five feet wide.**

Landscaping separating the street from the sidewalk should be five feet wide. There are benefits to putting driveway cross-slopes in the landscape area rather than across the sidewalk.

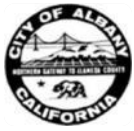
Elements such as street furniture, newspaper racks, bicycle parking racks, and trash bins should be kept in the buffer zone and should not impede a straight travel path along the sidewalk. Additionally, “meandering” sidewalks are discouraged. They may prove challenging for visually-impaired pedestrians and lengthen travel distance.

### Crossings

Pedestrian crossings generally fall into two categories: controlled and uncontrolled. Controlled crossings include signalized locations and stop-controlled crossings (both all-way stops and stop-controlled approaches on two- and three-way stops.) Uncontrolled crossings include both intersection and mid-block locations.

Pedestrian-friendly crossings are:

- **Compact:** A good rule to follow is “never design more than you need.” Keep turning radii tight; discourage free-right turns; and include pedestrian refuge islands or other special devices at especially wide crossings.
- **Visible:** The pedestrian crossing should be clearly-marked. Maintaining a high-visibility crossing creates an intuitive and safe environment for all users. Visibility also applies to sight distance. Pedestrians should be clearly visible by motorists up to 250 feet away.
- **Useful:** One of the first steps in creating an uncontrolled crossing, especially for mid-block locations, is to determine need and location. While identifying walking “desire lines,” or the places where the most pedestrians want to cross, can present special challenges, it is essential in order to ensure a cost-effective and well-used crossing.



- **Safe:** A common misperception about marked uncontrolled crossings is that they give pedestrians a “false sense of security.” Recent research has concluded that not all marked uncontrolled crossings are less safe than uncontrolled crossings.

The following pages contain a toolbox of devices for use in various situations. The first toolbox applies to controlled crossings, and the second applies to uncontrolled crossing locations.

Controlled Crossings

Controlled crossings should be timed for a maximum walking speed of 3.0 feet per second of walk and flashing don’t walk time, measured from the top of the curb ramp on one side of the street to the top of the curb ramp on the opposite side of the street per the ADA Accessibility Guidelines. The FLASHING DON’T WALK, or pedestrian clearance interval, should be timed to a maximum walking speed of 3.5 feet per second. These crossing times have been approved by the National Committee on Uniform Traffic Control Devices and will be included in the 2009 version of the MUTCD. For other guidelines concerning push-buttons and actuated pedestrian signals, see *Section I Corner Zone*.

The table below summarizes the standard treatment for controlled crossings:

**TABLE F-3**

CONTROL TYPE	STANDARD TREATMENT	ENHANCEMENTS	DO NOT MARK
Signal	Advance 24” Limit Line four to seven feet before the crosswalk Dual white lines	Pedestrian refuge island Curb extensions Signal phasing treatments: <ul style="list-style-type: none"> <li>• Early Release</li> <li>• Scramble</li> </ul> Right-turn on red restrictions	Inadequate sight distance
Stop sign	Dual white lines Advanced unit line for stop approaches Advanced yield line for uncontrolled approaches In-street YIELD TO PEDESTRIANS signs	Triple-four or other high-visibility stencil Pedestrian refuge island Curb extensions	Inadequate sight distance



There are a number of innovative treatments for pedestrians at signalized intersections, mostly related to pedestrian signals. At locations with high pedestrian volumes and pedestrian-motorist conflicts, the following measures are means to enhance the safety of pedestrian crossings:

#### High Numbers of Turning Vehicles

- Early Release or pedestrian lead-time, allows pedestrians to establish themselves in the crosswalk, reducing conflicts between pedestrians and turning vehicles.
- Special Pavement stencils such as “Pedestrians Look Left” or “Watch Turning Vehicles” stencil are used in Salt Lake City, Halifax, N.S., Canada, and the UK to remind pedestrians to be watchful. These stencils, used in conjunction with special signage, significantly reduced the number of pedestrians not looking for threats at intersections<sup>4</sup>. Additionally, high-visibility crosswalks help channelize pedestrians.
- Other special treatments include “Yield to Pedestrians” signs, and reduced corner radii to slow the speeds of right-turning vehicles. The curb radius should accommodate the expected amount and type of traffic for safe turning speeds. As the curb radius increases, incomplete stops become more frequent and drivers make turns at higher speeds.<sup>5</sup> Recommended ranges for curb radii are as follows:

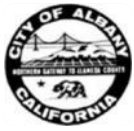
#### High Numbers of Pedestrians

- Pedestrian “scramble” phases, so called because pedestrians have a walk signal in every direction while vehicles have a red light on all approaches. This treatment is appropriate in central business districts where pedestrian volumes are exceptionally high.
- “No Right Turn on Red” restrictions for vehicles reduce pedestrian-motorist conflicts at locations with high numbers of pedestrians, but makes vehicle circulation less convenient and may cause traffic diversions. This type of treatment needs to be considered on a case-by-case basis.
- Advance stop lines or yield lines are stop or yield bars placed four feet in advance of the crosswalk. Advance stop lines or yield bars should be considered based on pedestrian volumes, generators and safety concerns relevant to a specific crossing.

---

<sup>4</sup> Van Houten, Ron et al, “Special Signs and Pavement Markings Improve Pedestrian Safety,” *ITE Journal*, December 1996.

<sup>5</sup> Kulash, William M., Residential Streets, Urban Land Institute, 2001.



## Wide intersections

Countdown signals are useful at signalized locations and are now required in all signal modifications or new signals. At wide streets with long clearance intervals, the countdown signal effectively communicates the amount of time left to cross the street. At streets with medians, there should be adequate crossing time for the pedestrian to traverse the entire distance and countdown signals should be used as a default.

## Exceptions

The following situations are exceptions to the practice of marking crosswalks on all controlled approaches:

- Crossing locations with heavy right- or left-turn volumes that occur at the same time as pedestrians cross the path of the turning vehicle where protected signal phasing (such as left-turn arrows) or other solutions outlined above are infeasible.<sup>6</sup>
- Intersections with inadequate sight distances<sup>7</sup> for pedestrians. Elimination of crosswalks in these instances should only occur after other solutions have been deemed infeasible.
- Heavy or light rail crossings. The California Public Utilities Commission (CPUC) is responsible for regulating at-grade crossings. The PUC no longer allows new at-grade crossings (pedestrians and cars crossing rail tracks) unless there are extraordinary circumstances.



## **BUFFER ZONE**

Planting strips, parking lanes, and even bicycle lanes provide a buffer between pedestrians on the sidewalk and motor vehicle traffic. Planting strips require a minimum of five feet, although six feet is more desirable, especially for larger trees.

**Sidewalks on commercial streets should provide a minimum five foot buffer zone in addition to an eight foot sidewalk.**

Buffer strips are recommended to eliminate driveway cross slopes in the sidewalk, improve pedestrian comfort, and offer landscape/shade opportunities.

---

<sup>6</sup> Alternative pedestrian crossings should be identified and it may be necessary to install barrier treatments to reinforce that pedestrians should not cross at the location without a marked crosswalk.

<sup>7</sup> Unrestricted sight distance of pedestrians by motorists should be at least ten times the speed limit (for example, 250 feet for a street with a speed limit of 25 miles per hour.)

## G. GUIDELINES FOR THE PLACEMENT OF CROSSWALKS

**NOTE:** The final design of the improvements at specific locations must be left to the professional engineer who will be responsible for the design and who will be charged with exercising good engineering judgment that meets acceptable standard of care for pedestrian, bicycle and vehicular traffic.

This crosswalk policy will assist the City of Albany in making decisions about where basic crosswalks (two stripes) can be marked; where crosswalks with special treatments, such as high visibility crosswalks, flashing beacons, and other special features, should be employed; and where crosswalks will not be marked due to safety concerns resulting from volume, speed, or sight distance issues.

This document contains a toolbox of elements to improve pedestrian mobility, visibility, and safety at uncontrolled locations. In addition to standard tools, the toolbox includes very promising devices, such as the HAWK/ Pedestrian Hybrid Beacon (approved under the 2009 Federal *Manual on Uniform Traffic Control Devices, MUTCD*) and the Rectangular Rapid Flashing Beacon (approved at the Federal level for experimental use).

Based on research from the National Cooperative Highway Research Program and Federal Highway Administration, among other best practice documents, this toolbox provides guidance about the type of treatments appropriate on various streets and under various conditions. While the strategies in the toolbox reflect best practices and local priorities, the toolbox guidance is not meant to replace engineering judgment. Each situation is unique and walking safety treatments must be selected on a case-by-case basis.





## DETERMINING WHERE AND HOW TO MARK UNCONTROLLED CROSSWALKS

The first step in identifying candidate marked crosswalk locations at an uncontrolled crossing (without a stop sign or signal) is to identify the places people would like to walk (walking desire lines), which are affected by local land uses (homes, schools, parks, commercial establishments, etc.) and the location of transit stops. This information forms a basis for identifying pedestrian crossing treatment areas and prioritizing such treatments, thereby creating a convenient, connected, and continuous walking environment.

The second step is identifying the safest locations for people to cross. Of all road users, pedestrians have the highest risk because they are the least protected. National statistics indicate that pedestrians represent 14 percent of all traffic incident fatalities while walking accounts for only three percent of total trips. Pedestrian-involved collisions occur most often when a pedestrian is attempting to cross the street at an intersection or mid-block location.<sup>1</sup>

Several major studies of pedestrian-involved collision rates at marked and unmarked crosswalks have been conducted. In 2002, the FHWA published a comprehensive report on the relative safety of marked and unmarked crossings.<sup>2</sup> In 2006, another study was completed that further assists engineers and planners in selecting the right treatment for marked crosswalks based on studies of treatment effectiveness.<sup>3</sup> With these studies as a backdrop, this document presents a variety of treatment options to mitigate safety, visibility, or operational concerns at specific locations.

## TREATMENTS AT UNCONTROLLED LOCATIONS

This section presents best practices for the installation of marked crosswalks at uncontrolled intersection and mid-block locations.



Image source: [www.cers-safety.com](http://www.cers-safety.com)  
[www.pedbikeimages.org](http://www.pedbikeimages.org)

<sup>1</sup> *Pedestrian Crash Types, A 1990's Information Guide*, FHWA; This paper analyzed 5,076 pedestrian crashes that occurred during the early 1990's. Crashes were evenly selected from small, medium, and large communities within six states: California, Florida, Maryland, Minnesota, North Carolina, and Utah.

<sup>2</sup> Zegeer, C.V., J.R. Stewart, H.H. Huang and RA. Lagerwey. "Safety Effects of Marked vs. Unmarked Crosswalks at Uncontrolled Locations: Executive Summary and Recommended Guidelines." Report No. FHWA-RD-01-075. Washington, DC, USA: Federal Highway Administration, March 2002. [http://www.walkinginfo.org/pdf/r&d/crosswalk\\_021302.pdf](http://www.walkinginfo.org/pdf/r&d/crosswalk_021302.pdf).

<sup>3</sup> Fitzpatrick, Kay, *et al.* *Improving Pedestrian Safety at Uncontrolled Crossings*. TCRC Report 112/NCHRP Report 562. 2006. [http://onlinepubs.trb.org/onlinepubs/nchrp/nchrp\\_rpt\\_562.pdf](http://onlinepubs.trb.org/onlinepubs/nchrp/nchrp_rpt_562.pdf).

### ***When to Install Marked Crosswalks***

The following is the recommended practice for providing walking treatments at uncontrolled intersections and mid-block locations. The most common crosswalk of this type will be at intersections where a minor side street is stop controlled and a major street is uncontrolled.

Crossings should be marked where all of the following occur:

- Sufficient demand exists to justify the installation of a crosswalk (see Demand Considerations below)
- The location has sufficient sight distance (as measured by stopping sight distance calculations) and/or sight distance will be improved prior to crosswalk marking
- Safety considerations do not preclude a crosswalk

### Demand Considerations

Uncontrolled and mid-block crossings should be identified as a candidate for marking if there is a demonstrated need for a crosswalk. Charts G-1 and G-2 provide a visual summary of the demand considerations, including suggested threshold values in some cases. Engineering judgment will ultimately be used to select locations appropriate for a marked, uncontrolled crossing.

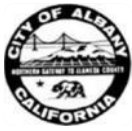


Chart G-1. Recommended Selection Process for Uncontrolled and Mid-Block Crosswalk Locations

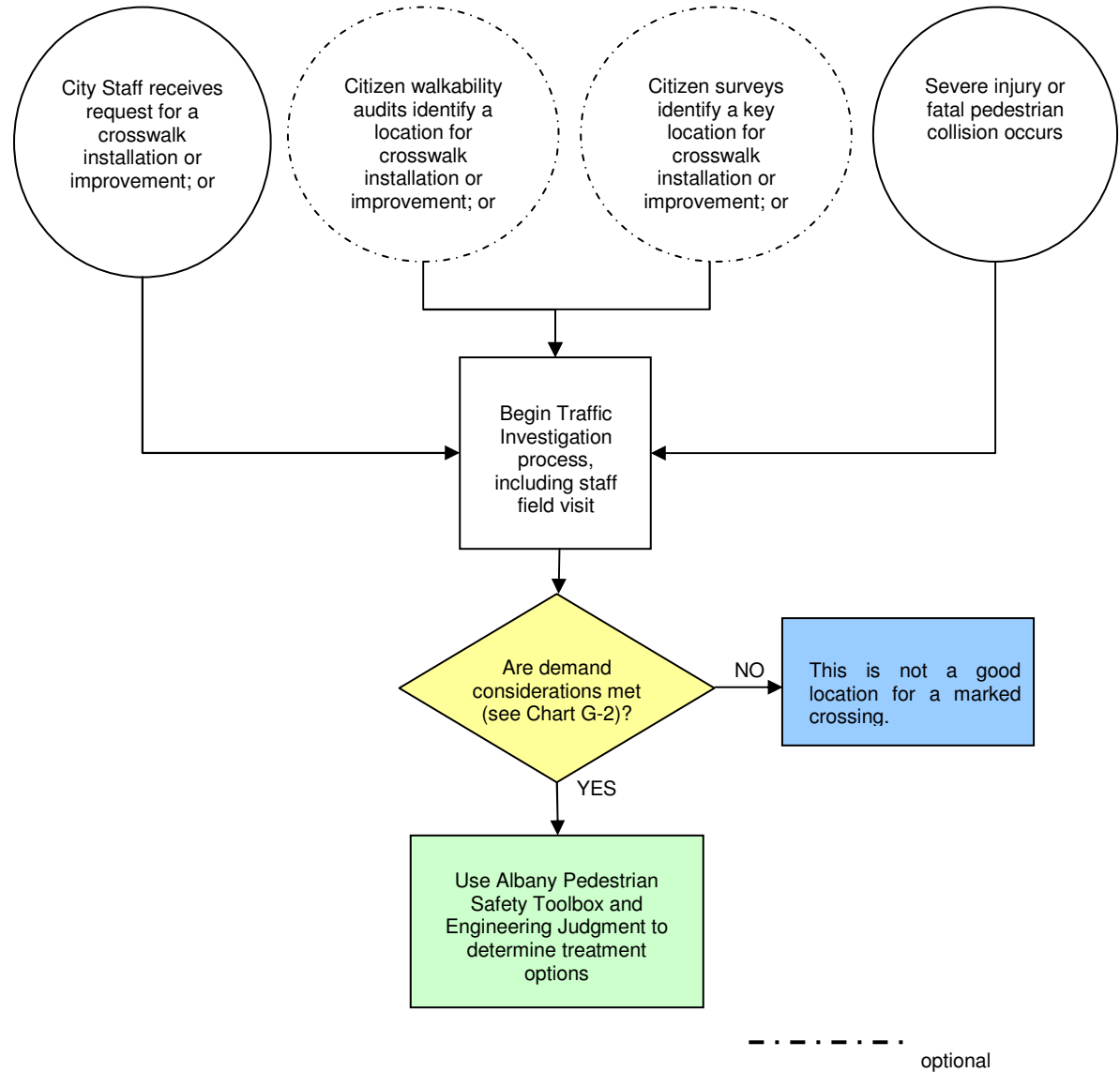
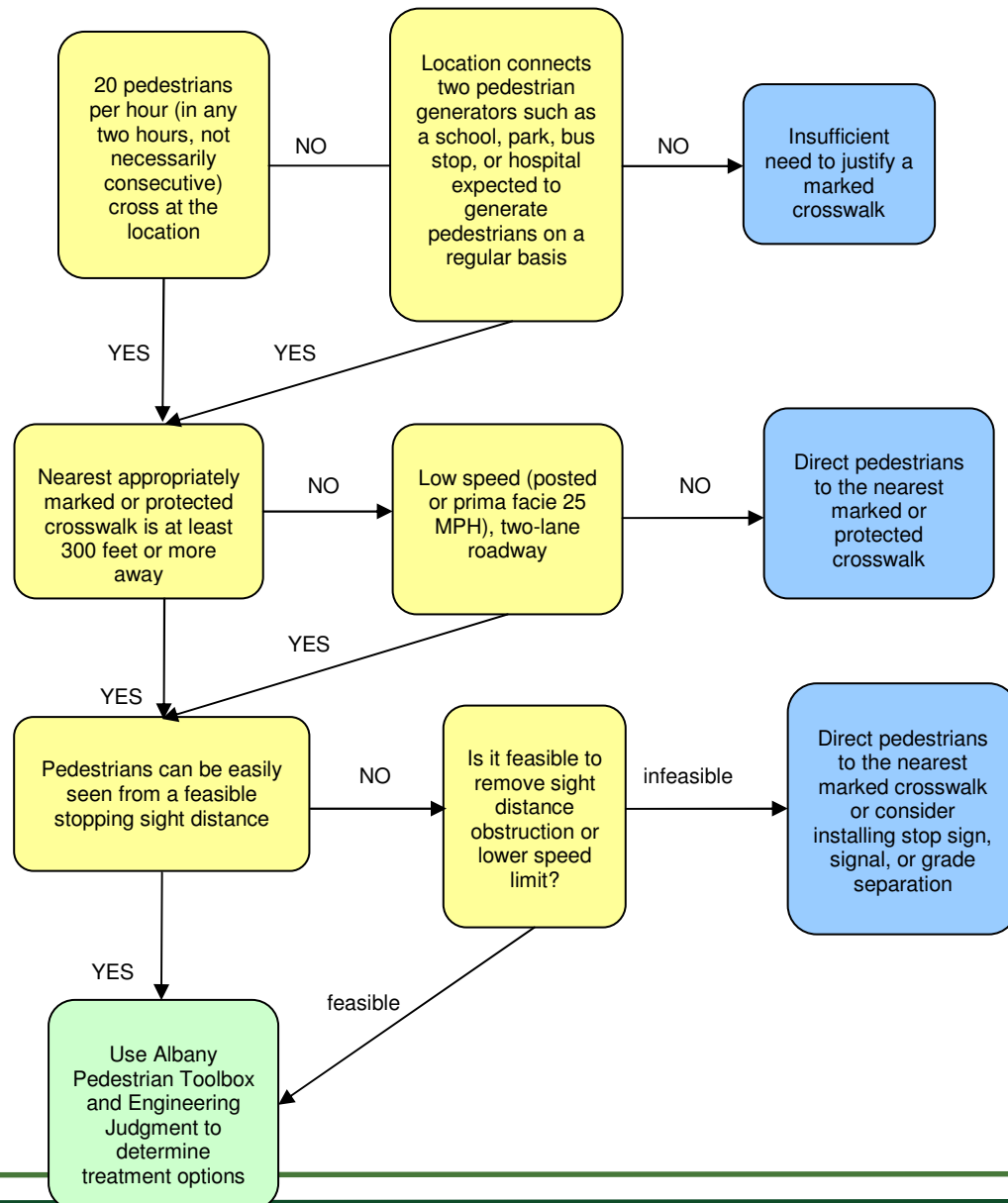


Chart G-2. Feasibility Analysis for Treatments at Uncontrolled Locations

Note: Where no engineering action is recommended in Chart G-2, consider applicable education and enforcement efforts.





### ***Considerations for Multi-Lane, High Volume, and/or High Speed Locations***

At uncontrolled locations, enhanced treatments beyond striping and signing may be needed for candidate marked crosswalk locations under the following conditions<sup>4</sup>:

- Multi-lane streets (three or more lanes); or
- Two-lane streets with daily traffic volumes (ADT) greater than 12,000; or
- Streets with posted speed limit exceeding 30 miles per hour

Additional funding sources should be identified as needed for these enhancements. Failing to provide an enhanced crosswalk and/or removing a crosswalk should be an option of last resort.

### ***Crosswalk Location and Tool Feasibility Analysis***

Charts G-1 and G-2 describe the overall procedures from the moment City staff receives a request for a new marked crosswalk (or considers removing an existing marked crosswalk) to the installation of the treatment. As described, the first steps to determine the appropriate location and treatment for the crosswalk include a staff field visit.

### ***Treatment Identification***

Based on the results of Charts G-1 and G-2, this Toolbox may be used to identify potential treatments at a candidate crosswalk location. If a candidate uncontrolled location is determined to be appropriate for a marked crossing, the preferred treatments should be provided at the subject location, as appropriate.




Table G-1 includes the list of preferred treatments for uncontrolled locations. Unless otherwise noted, these treatments are appropriate for all roadway cross-sections

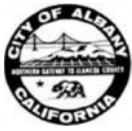
---

<sup>4</sup> See Appendix A discussion



**TABLE G-1 – PREFERRED WALKING TREATMENTS FOR UNCONTROLLED LOCATIONS**

Type	Measure	Description
Geometrics/ ADA Treatments	Directional Curb Ramp with Truncated Domes  <i>Image Source: Suzanne Pullen</i>	Where right-of-way is available, directional curb ramps are installed at two per corner and guide pedestrians in to the crosswalk they would utilize to cross the street. Truncated domes provide a tactile signal to the visually impaired that they are leaving the sidewalk area. Exceptions for directional curb ramps may be allowed when physical considerations such as existing drainage or required turn radius deem infeasible. Selecting directional curb ramps as a preferred treatment does not call for retrofit of existing curb ramps, rather installation will be done opportunistically in scenarios such as grant funding, development review, new construction, and reconstruction.
Striping	High-Visibility Marked Crosswalk  <i>Image source: www.walkinginfo.org/pedsafe/</i>  <i>Image source: Fehr &amp; Peers</i>	High-visibility markings include a family of crosswalk striping styles such as the "ladder" and the "triple-four."



**TABLE G-1 – PREFERRED WALKING TREATMENTS FOR UNCONTROLLED LOCATIONS**


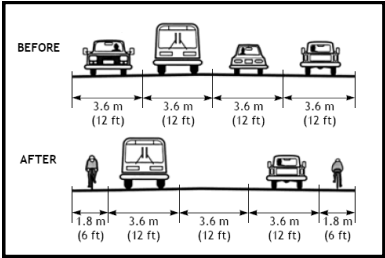

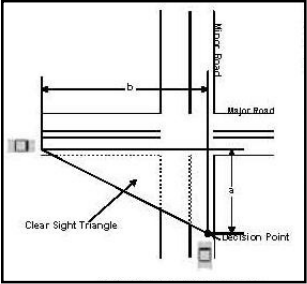
Type	Measure	Description
Striping	Advance Yield Limit Line (multi-lane roadways)  <i>Image Source: City of Pasadena</i>	Yield limit lines (also referred to as “sharks’ teeth”) are placed in advance of marked, uncontrolled crosswalks.
Road Diet	Road Diet (multi-lane roadways)  <i>Image Source: www.tfhr.gov/</i>	The number of lanes of travel is reduced by widening sidewalks, adding bicycle and parking lanes, and converting parallel parking to angled or perpendicular parking. A road diet is recommended for consideration in all scenarios with four or more lanes of traffic and a daily traffic volume of less than 15,000 vehicles (ADT).

TABLE G-1 – PREFERRED WALKING TREATMENTS FOR UNCONTROLLED LOCATIONS

Type	Measure	Description
Streetscape	Pedestrian-Scale Lighting  <p><i>Image source: www.ci.mil.wi.us</i></p>	Pedestrian-scale lighting improves pedestrian visibility.
Geometrics	Removal of Sight Distance Obstructions  <p><i>Image source: Nazir Lalani</i></p>	If objects impede sight distance, this may result in an unsafe condition when motorists and pedestrians are unable to see each other. Items such as parked cars, signage, landscaping, fencing, and street furniture should be placed in a location that will not obstruct sight distance.



**TABLE G-1 – PREFERRED WALKING TREATMENTS FOR UNCONTROLLED LOCATIONS**



Type	Measure	Description
Geometrics	Refuge Island  <i>Image Source: City of Pasadena</i>	Raised islands are placed in the center of the roadway, separating opposing lanes of traffic with cutouts or ramps for accessibility along the walking path. Median refuge islands are recommended where right-of-way allows and conditions warrant.
Signage	Advanced Warning Signs  <i>Image source: <a href="http://mutcd.fhwa.dot.gov">http://mutcd.fhwa.dot.gov</a></i>	High-visibility fluorescent yellow green signs are made of the approved fluorescent yellow-green color and posted at crossings to increase the visibility of a pedestrian crossing.

Table G-2 provides a summary of the enhanced treatments for uncontrolled crosswalks. Enhanced treatments should be selected based on site-specific characteristics and engineering judgment.

Recent research on this topic has found that primary considerations for the provision of marked crossings at uncontrolled locations include traffic volumes, the presence of a median, the number of lanes to be crossed, and posted speed limits. As indicated above, multi-lane locations, and locations that experience high travel volumes and speeds are candidates for enhanced treatments, as research has indicated that for uncontrolled locations the provision of signage and striping may be inadequate.<sup>5</sup>

---

<sup>5</sup> Zegeer, C., J. Stuart, and H. Huang, Safety Effects of Marked vs. Unmarked Crosswalks at Uncontrolled Crossing Locations, Federal Highway Administration, Washington, DC, 2001



**TABLE G-2 – ENHANCED WALKING TREATMENTS FOR UNCONTROLLED LOCATIONS**





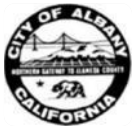


Type	Measure	Description
Geometrics	<p data-bbox="548 370 688 394">Narrow Lanes</p>  <p data-bbox="590 706 1016 730"><i>Image source: <a href="http://www.walkinginfo.org/pedsafe/">www.walkinginfo.org/pedsafe/</a></i></p>	<p data-bbox="1094 500 1423 613">Narrow lanes have a calming effect and reduce the distance pedestrians must travel when crossing.</p>
Geometrics	<p data-bbox="548 781 709 805">Curb Extensions</p>  <p data-bbox="663 1154 932 1179"><i>Image source: Fehr &amp; Peers</i></p>	<p data-bbox="1094 873 1423 1101">Also known as a pedestrian bulb-out, this traffic-calming measure is meant to slow traffic and increase driver awareness of pedestrians. It consists of an extension of the curb into the street, making the pedestrian space (sidewalk) wider.</p>

TABLE G-2 – ENHANCED WALKING TREATMENTS FOR UNCONTROLLED LOCATIONS

Type	Measure	Description
Geometrics	<p data-bbox="548 367 877 391">Split Pedestrian Crossover (SPXO)</p>  <p data-bbox="659 797 951 821"><i>Image Source: www.tfsrc.gov/</i></p>	<p data-bbox="1089 440 1423 813">This measure is similar to traditional median refuge islands; the difference is that the crosswalks in the roadway are staggered such that a pedestrian crosses half the street and then walks toward traffic to reach the second half of the crosswalk. This measure must be designed for accessibility by including rails and truncated domes to direct sight-impaired pedestrians along the path of travel.</p>
Geometrics	<p data-bbox="548 894 722 919">Raised Crosswalk</p>  <p data-bbox="611 1268 982 1292"><i>Image Source: www.saferoutesinfo.org</i></p>	<p data-bbox="1089 1016 1423 1187">A crosswalk with a surface elevated above the travel lanes, attracting drivers' attention, encouraging lower speeds, and improving the visibility of pedestrians.</p>





**TABLE G-2 – ENHANCED WALKING TREATMENTS FOR UNCONTROLLED LOCATIONS**

Type	Measure	Description
Geometrics	<p data-bbox="548 367 869 391">Pedestrian Overpass/ Underpass</p>  <p data-bbox="596 800 989 849"><i>Image source: omahamidcenturymodern.blogspot.com</i></p>	<p data-bbox="1089 451 1425 768">This measure consists of a walking-only overpass or underpass over a roadway. It provides complete separation of pedestrians from motor vehicle traffic, normally where no other walking facility is available, and connects off-road trails and paths across major barriers. The device is recommended only where topography supports its use.</p>
Signage	<p data-bbox="548 865 890 889">In-Street Pedestrian Crossing Signs</p>  <p data-bbox="821 1011 974 1060"><i>Image source: www.seton.com</i></p>	<p data-bbox="1089 987 1425 1214">This measure involves posting regulatory pedestrian signage on lane edge lines and/or road centerlines. The In-Street Pedestrian Crossing sign may be used to remind road users of laws regarding right of way at an unsignalized pedestrian crossing.</p>



**TABLE G-2 – ENHANCED WALKING TREATMENTS FOR UNCONTROLLED LOCATIONS**

Type	Measure	Description
Signage	<p>Crosswalk Flags</p>  <p><i>Image source: www.walkinginfo.org</i></p>	<p>Brightly-colored removal flags are placed at crosswalks to increase pedestrian visibility and clearly communicate their desire to cross the street.</p>
Signal Treatment	<p>In-Roadway Warning Lights</p>  <p><i>Image Source: www.tfhr.gov/</i></p>	<p>Both sides of a crosswalk are lined with pavement markers, often containing an amber LED strobe light. The lights may be push-button activated or activated with pedestrian detection.</p>



**TABLE G-2 – ENHANCED WALKING TREATMENTS FOR UNCONTROLLED LOCATIONS**




Type	Measure	Description
Signal Treatment	<p>Flashing Beacons</p>  <p><i>Image source: tti.tamu.edu</i></p>	<p>Flashing amber lights are installed on overhead or post-mounted signs, in advance of the crosswalk or at the entrance to the crosswalk.</p>
Signal Treatment	<p>Stutter Flash (Rectangular Rapid Flashing Beacon)</p>  <p><i>Image source: mutcd.fhwa.dot.gov</i></p>	<p>The Flashing Beacon is enhanced by replacing the traditional slow flashing incandescent lamps with rapid flashing LED lamps. The beacons may be push-button activated or activated with pedestrian detection. This treatment is not currently approved for use in California, but has provisional approval for use at the Federal level because of recent studies suggesting its effectiveness.</p>

TABLE G-2 – ENHANCED WALKING TREATMENTS FOR UNCONTROLLED LOCATIONS

Type	Measure	Description
Signal Treatment	<p>HAWK/ Pedestrian Hybrid Beacon</p>  <p><i>Image Source: www.tfsrc.gov/</i></p>	<p>HAWK (High Intensity Activated Crosswalks) are pedestrian-actuated signals that are a combination of a beacon flasher and a traffic control signal. When actuated, HAWK displays a yellow (warning) indication followed by a solid red light. During pedestrian clearance, the driver sees a flashing red “wig-wag” pattern until the clearance interval has ended and the signal goes dark. While included in the Federal MUTCD, this treatment is not currently approved for use in California.</p>
Signal Treatment	<p>Pedestrian Signal</p>  <p><i>Image source: City of Pasadena</i></p>	<p>Conventional traffic control devices with warrants for use based on the MUTCD (a new warrant is provided in the 2009 Federal MUTCD).</p>



Safety effectiveness studies have been conducted for many of the devices in Table G-2. Based on these studies, Table G-3 provides the conditions under which the enhanced walking treatments for uncontrolled intersections should typically be applied. Level 1 represents a minor intervention, appropriate for situations with lower speeds and traffic volumes and high driver yielding rates. Higher levels represent more significant interventions, as may be needed on higher speed or volume roadways, wider roadways, and roadways where motorists are less likely to yield to pedestrians. Treatments may be combined with higher level treatments added to lower level treatments (i.e., flashing beacons with curb extensions).

**TABLE G-3 – APPLICATION OF ENHANCED TREATMENTS FOR UNCONTROLLED LOCATIONS**

Level 1: Basic		Level 2: Low Speeds ≤ 30 MPH	Level 3: Higher Speeds > 30 MPH		Level 4: Higher Speeds (>30 MPH) and Volumes (12,000 + ADT)
All Widths	Two to Three Lanes Only	Two to Three Lanes Only	Two to Three Lanes Preferred	Four or More Lanes Preferred	All Widths
Narrow Lanes	In-Street Signs	Raised Crosswalk	Overhead/ Post Mounted Flashing Beacons	Stutter Flash (RRFB)*	Pedestrian Signal
Refuge Island/ SPXO		In-pavement Flashers		Pedestrian Hybrid (HAWK) Beacon*	Under/ Overpass
Curb Extensions		Crossing Flags (with Level 1 treatments)			

## H. BICYCLE DESIGN GUIDELINES<sup>1</sup>

This chapter identifies guidelines for the design of bikeways and bicycle parking facilities in the City of Albany. The appropriate design of bicycling facilities is an integral component of encouraging the public to bicycle for commuting and recreational purposes. Good design affects the experience, enjoyment and comfort for bicyclists, and should ultimately provide the highest level of safety possible for all road and shared-use path users. The Albany Active Transportation Plan envisions a two-part bicycling network, one that accommodates utilitarian trips, such as those between home and work, and one that accommodates recreational trips.

Bikeway planning and design in California typically relies on the guidelines and design standards established by Caltrans and documented in “Chapter 1000: Bikeway Planning and Design” of the Highway Design Manual (California Department of Transportation, 2006). Chapter 1000 follows standards developed by the American Association of State Highway and Transportation Officials (AASHTO) and the Federal Highway Administration (FHWA) and identifies specific design standards for various conditions and bikeway-to-roadway relationships. These standards provide a good framework for future implementation, but depending on the circumstances may not always be feasible given specific constraints. Likewise, these standards can often be expanded. Whatever the case may be, local jurisdictions must be protected from liability concerns so most agencies adopt the Caltrans or AASHTO standards as a minimum. Caltrans standards provide for three distinct types of bikeway facilities, as generally described below.

**Table H-1. Types of Bicycle Facilities**

<p><b>Class I: Shared Use Path</b></p> <p>These facilities provide a completely separate right-of-way and are designated for the exclusive use of bicycles and pedestrians with vehicle cross-flow minimized.</p>
<p><b>Class II: Bicycle Lane</b></p> <p>Bicycling lanes provide a restricted right-of-way and are designated for the use of bicycles with a striped lane on a street or highway. Bicycling lanes are generally five feet wide. Vehicle parking and vehicle/pedestrian cross-flow are permitted.</p>
<p><b>Class III: Bicycle Route</b></p> <p>These bikeways provide a right-of-way designated by signs or pavement markings for shared use with pedestrians or motor vehicles.</p>

<sup>1</sup> The final design of the improvements at specific locations must be left to the professional engineer who will be responsible for the design and who will be charged with exercising good engineering judgment that meets acceptable standard of care for pedestrian, bicycle, and vehicular traffic. This Appendix is meant to guide the design process

This chapter presents design guidelines for the following topics:

- Class I Shared-Use Path**
  - Shared-Use Path Structures
  - Crossing Treatments
  - Path Amenities
- Class II Bicycle Lanes**
  - Bicycling lanes next to Parallel Parking
  - Bicycling lanes next to Angled Parking
  - Bicycling lanes Without Parking
  - Bicycling lanes on Hills
  - Bicycling lanes at Intersections
  - Bicycling Lane Markings
  - Treatments at Interchanges, Bridges and Tunnels
  - Bicycle Loops and Detectors
- Class III Bicycle Routes**
  - Bicycling Boulevards
  - Share the Road Markings
- Bicycling Signage**
  - Wayfinding/Destination Signage
  - Signs for Shared Roadways
- Maintenance Standards**
  - Utility Covers and Construction Plates

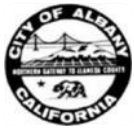
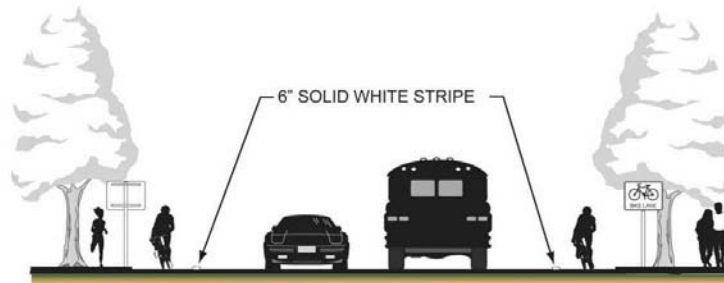


Figure H-1. Types of Bicycle Facilities



**CLASS I BIKEWAY (Bike Path)**

Provides a completely separated right-of-way for the exclusive use of bicycles and pedestrians with crossflow minimized.



**CLASS II BIKEWAY (Bike Lane)**

Provides a striped lane for one-way bike travel on a street or highway.



**CLASS III BIKEWAY (Bike Route)**

Provides for shared use with pedestrian or motor vehicle traffic.

## CLASS I SHARED USE PATH

Class I bikeways are typically called bicycling paths, multi-use or shared use paths and are completely separated from roads by buffers (five feet or more) or barriers. Cross traffic by motor vehicles should be minimized along bicycling paths to avoid conflicts. Bicycling paths can offer opportunities not provided by the road system by serving as both recreational areas and/or desirable commuter routes.

According to the AASHTO standards, two-way bicycling paths should be ten feet wide under most conditions, with a minimum two-foot wide graded area on both sides. In constrained areas, an eight-foot wide path may be adequate. Bicycling paths are usually shared with pedestrians and if pedestrian use is expected to be significant, the path should be greater than ten feet, preferably twelve feet wide.

Where possible, bicycling paths should have an adjacent four-foot wide unpaved area to accommodate joggers. This jogging path should be placed on the side with the best view, such as adjacent to the waterfront or other vista (see Figure H-2). Where equestrians are expected a separate facility should be provided.

Decomposed granite, which is a better running surface for preventing injuries, is the preferred surface type for side areas and jogging path, while asphaltic concrete or Portland cement concrete should be used for the bicycling path. A yellow centerline stripe may be used to separate opposite directions of travel. A centerline strip is particularly beneficial to bicycling commuters who may use unlighted bicycling paths after dark.

Sidewalks and meandering paths are usually not appropriate to serve as bicycling paths because they are primarily intended to serve pedestrians, generally do not meet Caltrans' design standards, and do not minimize motor vehicle cross flows. Where a shared use path is parallel and adjacent to a roadway, there should be a five-foot or greater width separating the path from the edge of roadway, or a physical barrier of sufficient height should be installed.

**Table H-2. Standards for Class I Facilities**

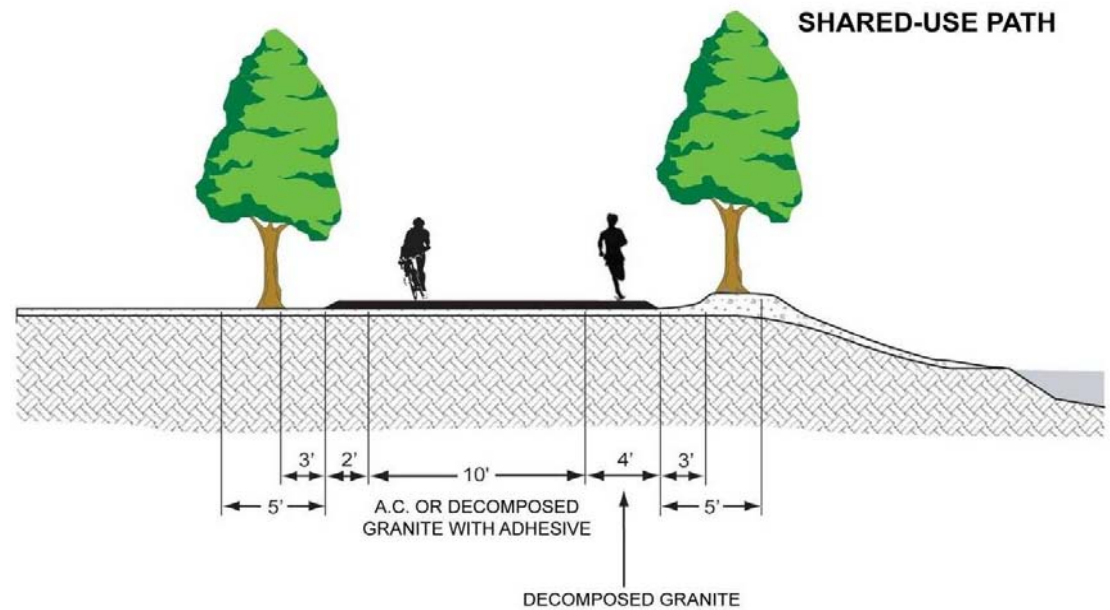
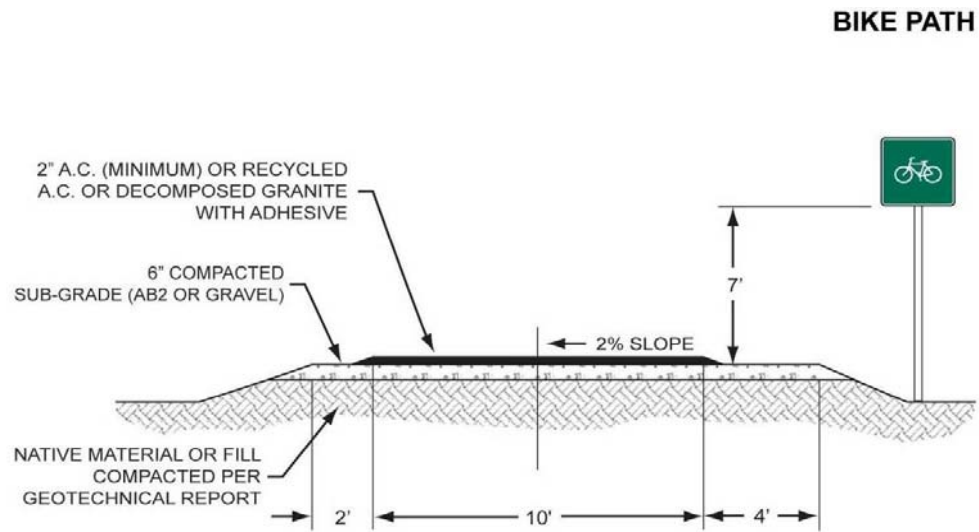
	AASHTO Standards	Preferred Standards*
Minimum Width	8.0'	10.0'
Vertical Clearance	8.0'	8.0'
Horizontal Clearance	2.0'	3.0'
Maximum Cross Slope	2.0%	2.0%

\*The City of Albany should decide what their preferred minimum standards are, and if they should exceed AASHTO standards.





Figure H-2. Typical Class I Path





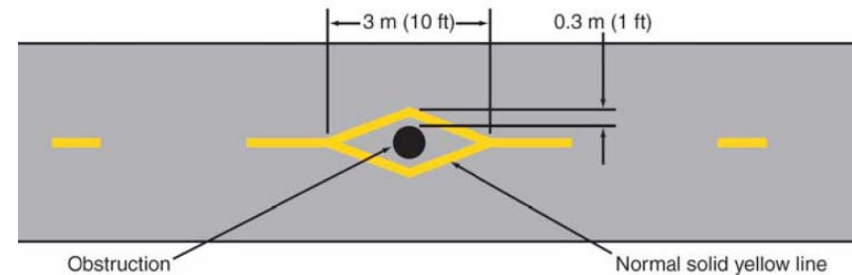
## Shared Use Path Structures

The following sections present typical design features found on Class I facilities.

### Bollards

Bollards can be placed at bicycling path access points to separate the path from motor vehicles and to warn and slow bicyclists as they approach street crossings. However, bollards are not recommended unless there is a demonstrated need for them (e.g., vehicle non-compliance). Thus, paths should be bollard-ready if the latter instance occurs.

The diagonal layout of bollards will make the space between the bollards appear narrower, slowing bicyclists and deterring motorcyclists from entering the trail. The bollards are spaced to provide access by people using wheelchairs (generally 5' apart). A trail sign post can be incorporated into the bollard layout. The image to the right shows the recommended striping and placement for bollards on shared use paths. Careful consideration should be taken before installing bollards as they can become obstacles for bicycles and result in fixed-object collisions. Where need for bollards is a possibility, but uncertain, install bollard-ready infrastructure, but delay installation of the bollard until a need is demonstrated.

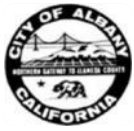


### Split Trailway

New 2009 California MUTCD standards discourage the use of bollards if other options are practical. If feasible, the path should be split by direction to go around a small center landscape feature. Rather than one 8' or 10' trail, the trail would be split into two 4' or 5' paths. This feature not only narrows the trail and prevents vehicles from entering, but also introduces a lateral shift for cyclists, encouraging slower speeds in conflict zones.

### Bridges

Bridges will be required wherever bicycling paths cross creeks and drainages. Crossings can utilize pre-fabricated bridges made from self-weathering steel with wood decks. Bridges should be a minimum of 8' wide (between handrails) and preferably as wide as the approaching trails. Openings between railings should be 4" maximum. Railing height should be a minimum of 42" high.



## Fencing

Fencing may be necessary on some bicycling paths to prevent path users from trespassing on adjacent lands, or to protect the user from dangerous areas. In areas near railway lines, safety may be a concern. Fences should maintain safety without compromising security. They should be tall enough to prevent trespassing, but they should maintain clear sight lines from the trail to the adjacent land uses. In areas where private residences are passed, privacy may be a concern. Screen fences should be used to maintain privacy of residents. Screen fences can be made of wood, concrete block or chain link if combined with vine planting. However, if fencing is used, there must be at least 2' of lateral clearance from the edge of the bicycling path.

## Curb ramps

Where curbs are present, curb ramps should be provided and be as wide as the entire path.

## Crossing Treatments

The following guidance is derived from the *AASHTO Guide to the Development of Bicycle Facilities*, the City of Seattle's *Bicycle Master Plan*, and the City of San Francisco's *Supplemental Bicycle Design Guidelines*.

Shared-use path crossings come in many configurations, with many variables: the number of roadway lanes to be crossed, divided or undivided roadways, number of approach legs, the speeds and volumes of traffic, and traffic controls that range from uncontrolled to yield, stop or signal controlled. Each intersection is unique and requires engineering judgment to determine the appropriate intersection treatment. The safe and convenient passage of all modes through the intersection is the primary design objective. Regardless of whether a pathway crosses a roadway at an existing roadway intersection, or at a new midblock location, the principles that apply to general pedestrian safety at crossings (controlled and uncontrolled) are transferable to pathway intersection design.

### Signs on Paths

Some jurisdictions have used STOP signs and BICYCLISTS MUST DISMOUNT signs to regulate bicycling traffic on shared-use paths. These signs are generally ineffective and result in frequent violations and disregard for other types of path signage.

When shared use paths cross roadways at intersections, the path should generally be assigned the same traffic control as the parallel roadway (i.e., if the adjacent roadway has a green signal, the path should also have a green/walk signal or if the parallel roadway is assigned the right-of-way with a stop or yield sign for the intersecting street, the path should also be given priority). At signalized intersections, if the parallel roadway has signals that are set to recall to green every cycle, the pedestrian signal heads for the path should generally be set to recall to walk. Countdown pedestrian signals should be installed at all signalized path crossings as signal heads are replaced. As required by the Manual on Uniform Traffic Control Devices, the walk signal for any path shall not conflict with a protected left- or right-turn interval. Bicyclists benefit from the safe passage that

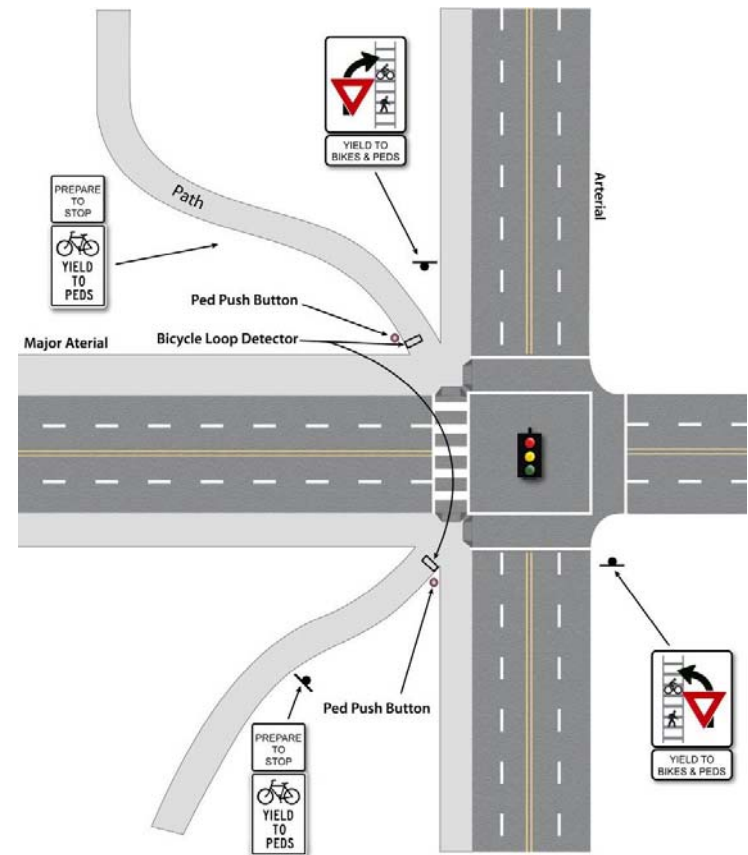


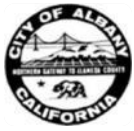
pedestrian signals provide by having a dedicated time during which to cross a roadway without having to yield to on-coming vehicle traffic.

Consideration should be given to providing a leading pedestrian interval at path crossings (i.e., three seconds of green/walk signal time are given to path users before any potentially-conflicting motor vehicle movements are given a green signal). This allows pedestrians and bicyclists to have a head start into the roadway to become more visible to turning traffic.

Where the signals for the parallel roadway are actuated, the path crossing will also need to be actuated. For shared-use path crossings, the minimum WALK interval may be 9-12 seconds to accommodate increased flow. The USE PED SIGNAL sign should be used at shared-use path crossings at signalized intersections. Pedestrian pushbuttons should be located within easy reach of both pedestrians and bicyclists, who should not have to dismount to reach the pushbutton.

The figure on the right illustrates the preferred approach for a shared use path at a controlled intersection. Paths should cross at the intersection to encourage use of the intersection crossing and have path users in the location where they are most anticipated. In many cases, a path will be separated from a roadway by between 20 and 50 feet. Locating path crossings along these alignments (that is 20 to 50 feet away from the intersection) creates a condition where vehicles do not expect to encounter a path crossing and vehicles leaving the intersection are accelerating away from it when they cross the path crossing. For signalized trail crossing, an advance loop detector within 100 feet of the intersection should be considered, so bicyclists can approach the intersection slowly but without having to stop.





## Unsignalized Intersections

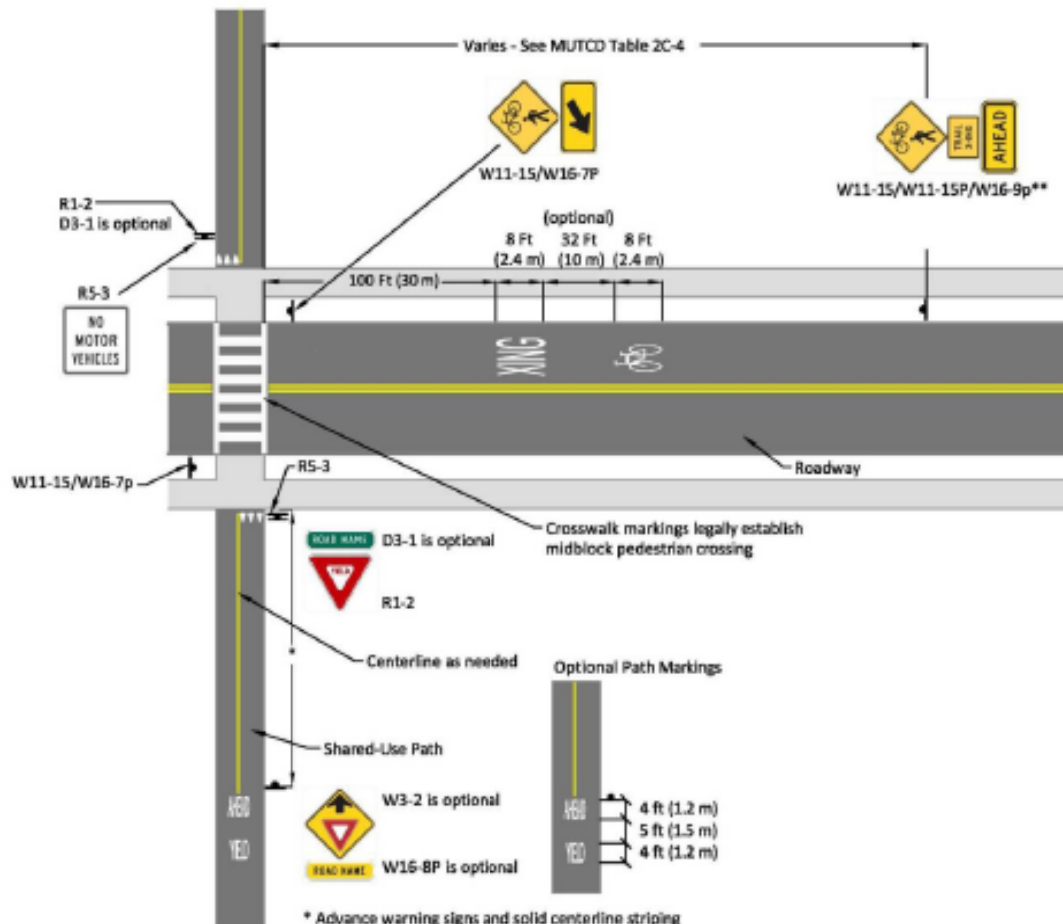
At unsignalized or stop controlled locations, an engineering study should be conducted to determine an appropriate way to control cross bicycle and pedestrian traffic. The following are general guidelines that can be used for these locations:

- If paths cross at intersections with all way stops, stop signs should be placed at each path approach.
- Consideration should be given to removing stop signs along continuous paths and their parallel roadways and controlling intersecting roadways with stop signs. An engineering study should be conducted before removing or adding any stop signs.
- At intersections with STOP signs controlling only one of the approaches, the trail should be assigned the same right-of-way as the parallel street. Stop signs should not be placed on the path approaches to the intersecting roadway if the parallel street has no stop signs.
- If the two streets have the same roadway classification, and the stop signs face the intersecting street that is parallel to the path, consideration should be given to reversing the stop sign placement, giving the right-of-way to the path and the parallel street. An engineering study should be conducted before reversing the stop sign placement.
- The decision of whether to use a traffic signal at a mid-block crossing should be primarily based on the latest version of the MUTCD Pedestrian Signal warrants.

At mid-block crossings, all path users (including bicyclists) should be included in calculating the “pedestrian volume” for the warrant procedure. While the CA MUTCD has not yet been updated with revised pedestrian-related signal warrants, the 2009 national MUTCD contains these revised warrants and should be used. When a path crossing meets the warrants, there may be other reasons why a signal is not necessary at the crossing. Where a decision has been made not to install a traffic signal at a mid-block path crossing, STOP or YIELD signs should be used to assign the right-of-way to the path or the roadway. The assignment of priority at a shared-use path/roadway intersection should be assigned with consideration of the relative importance of the path and the roadway; the relative volumes of path and roadway traffic; and the relative speeds of path and roadway users.

### Signage at Shared Use Path Crossings

Signage should be provided in advance of shared use path crossings to alert drivers to pedestrians and bicyclists using the path. Typically, these signs would be placed at the crossing with a downward pointing arrow, in advance of the crossing with an AHEAD warning, and in advance of intersections with roadways that are parallel to the path.



\* Advance warning signs and solid centerline striping should be placed at the required stopping sight distance from the roadway edge but not less than 50 feet (15m).

\*\*W11 series sign is required, supplemental plaques are optional



## Bicycle Signal Heads

Bicycle signal heads permit an exclusive bicycling-only signal phase and movement at signalized intersections. This takes the form of a new signal head installed with red, amber and green bicycle indications. Bicycle signals can be actuated with bicycle sensitive loop detectors, video detection or push buttons. Bicycle signals are an approved traffic control device in California, described in Part 4 and 9 of the CAMUTCD. The City of Albany may install bicycle signals at intersections with heavy bicycle volumes, on bicycling paths adjacent to intersections where heavy bicycle traffic in the crosswalk may conflict with turning vehicles, or at three-legged intersections where bikes may enter or exit a bicycling path at the intersection. Bicycle signal warrants could be considered when bicycle volumes exceed 50 per hour and vehicle volumes are greater than 1,000 vehicles per hour, or in locations that have a history of bicyclist-involved collisions (>2 in one calendar year), or in locations where a multi-use path intersects a roadway.

## Shared-Use Path Amenities

Furnishings along a shared-use path should be concentrated at specific points to form gathering nodes. These nodes occur at intersections between different path types, special viewpoints, or at distinctive landscape features. Shared-use path support facilities consist of staging areas, seating and tables, weather-protection structures, drinking fountains, waste receptacles, fencing, bicycle racks, interpretive and directional signage and restrooms.

## Staging Areas

Staging areas should be provided at path entrances. These areas should include basic information such as directional information and signage, bicycle parking, seating and waste receptacles. Restrooms, water fountains, and weather structures should be provided where practical and feasible. At path entrances where a substantial number of users are likely to drive, a parking lot should be provided; however, vehicle parking should be minimized to encourage non-motorized access to recreational facilities.

## Rest Areas

Rest areas are portions of paths that are wide enough to provide wheelchair users and others a place to rest while on trails without blocking continuing traffic. Rest areas are more effective when placed at intermediate points, scenic lookouts, or near other trail amenities. Most rest areas will have seating, shade, a place to rest bicycles, and waste receptacles. On longer paths, restrooms and/or water fountains may be desirable where feasible. The California State Parks Guidelines calls for rest areas every 200 feet on outdoor recreational routes with grades of no steeper than 8.3%. Accessible paths at steeper grades may require resting areas at greater frequency.



### **Seating**

Benches provide people of all ages and abilities a place to sit and rest along trails. Seating should be placed away from the path, at least 3 feet from the trail edge, to allow room for people to sit with outstretched legs. An area adjacent to the bench should be able to accommodate a wheelchair.

### **Waste**

Trash receptacles should be installed along bicycling paths at regular intervals, as well as at rest areas, path entrances, and seating areas, to encourage proper waste disposal and discourage littering.



## CLASS II BICYCLING LANES

This section includes guidelines for Class II bicycling lanes along roadways and at intersections. Most bicyclists benefit by having a lane that is separate from motor vehicle traffic, and bicycling lanes are typically used on streets with higher traffic volumes or greater speeds.

### Standards for Class II Facilities

The figures on the following pages illustrate the preferred widths for bicycling lanes in the following situations:

- Figure H-6. Next to Parallel Parking
- Figure H-7. Next to Back In Angled Parking
- Figure H-8. Without Parking
- Figure H-9. Buffered Bicycling Lane

**Standard Bicycling Lane:** Bicycling lanes should be designed to meet Caltrans standards, which require a minimum width of 5 feet. The preferred bicycling lane width is 6 feet. The preferred vehicle travel lane width is 10 feet; however, AC Transit prefers that any roadway with bus routes have 11-foot travel lanes. Signs that say BICYCLISTS WRONG WAY may be used on the back of bicycling lane signs or on separate posts to discourage wrong way riding.

**Shared Bicycling/Parking Lane:** If a bicycling lane is shared with a parking lane, the combined lane should be a minimum of 12.5 feet, with 13 feet desirable. This minimum combined lane should be striped with a 6-foot bicycling lane and 7 foot parking lane. The optimum combined lane should be a 6-foot bicycling lane and a 7-foot parking lane.

**Bicycling Lane without Parking:** In places where there is no on-street parking, the 6-foot preferred width applies. In exceptional circumstances where no other reasonable options exist or in retrofit situations, a 4-foot minimum is allowed as long as there is no on-street parking.

**Gutter Pans & Bicycling Lanes:** Where drainage or other obstructions constrict clearance between the vehicle travel lane and stormdrains, designers should take care to maintain a 2.5-foot clear longitudinal surface, free from drainage grates and other obstructions in order to give the cyclist adequate width to ride. It is preferable not to consider the gutter pan as clear surface.

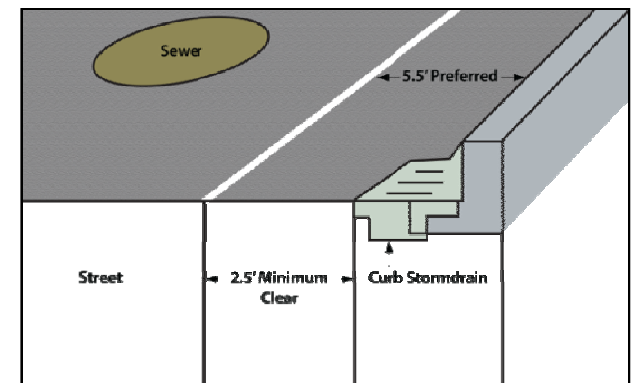




Figure H-3. **Bicycling Lanes Adjacent to Parallel Parking**

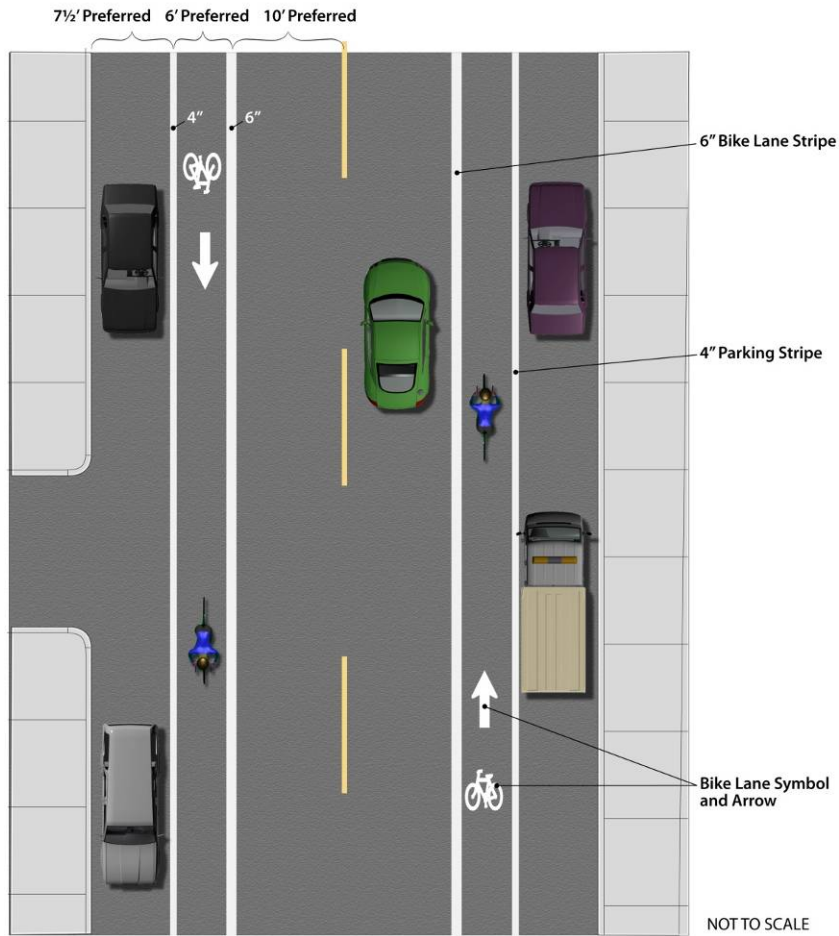
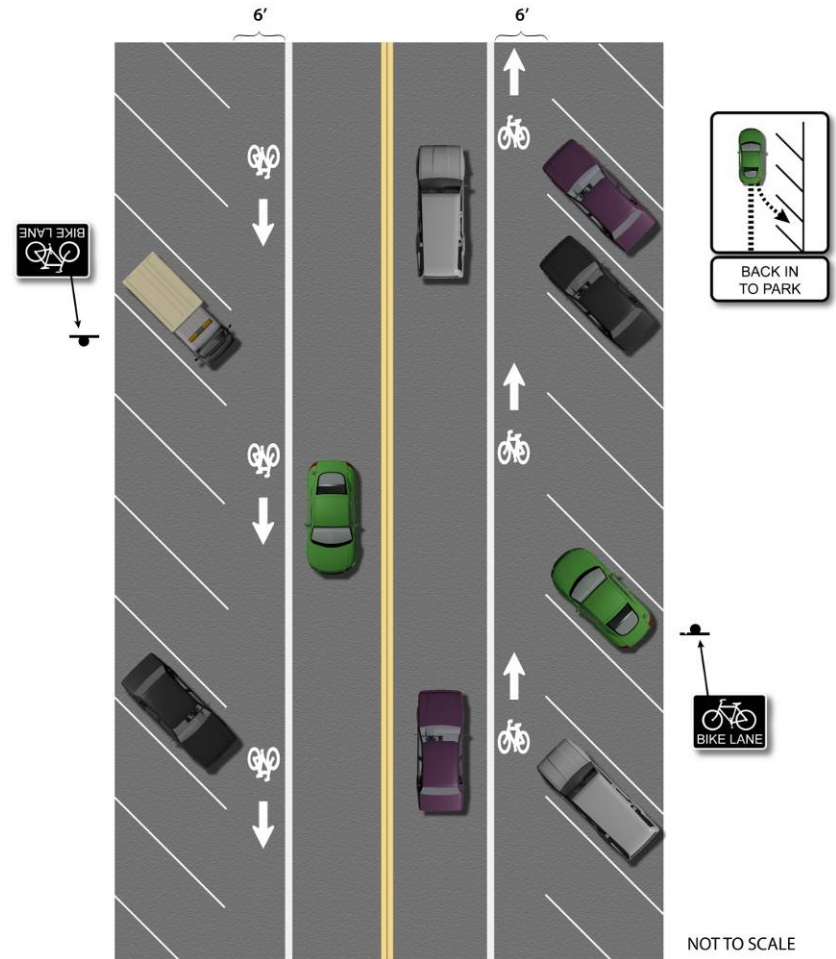


Figure H-4. **Bicycling lanes Adjacent to Back-In Angled Parking**



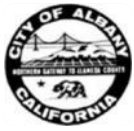


Figure H-5. **Bicycling lanes without Parking**

- 6' Preferred
- Need to Maintain  
2½' Ridable Surface. 10' Preferred

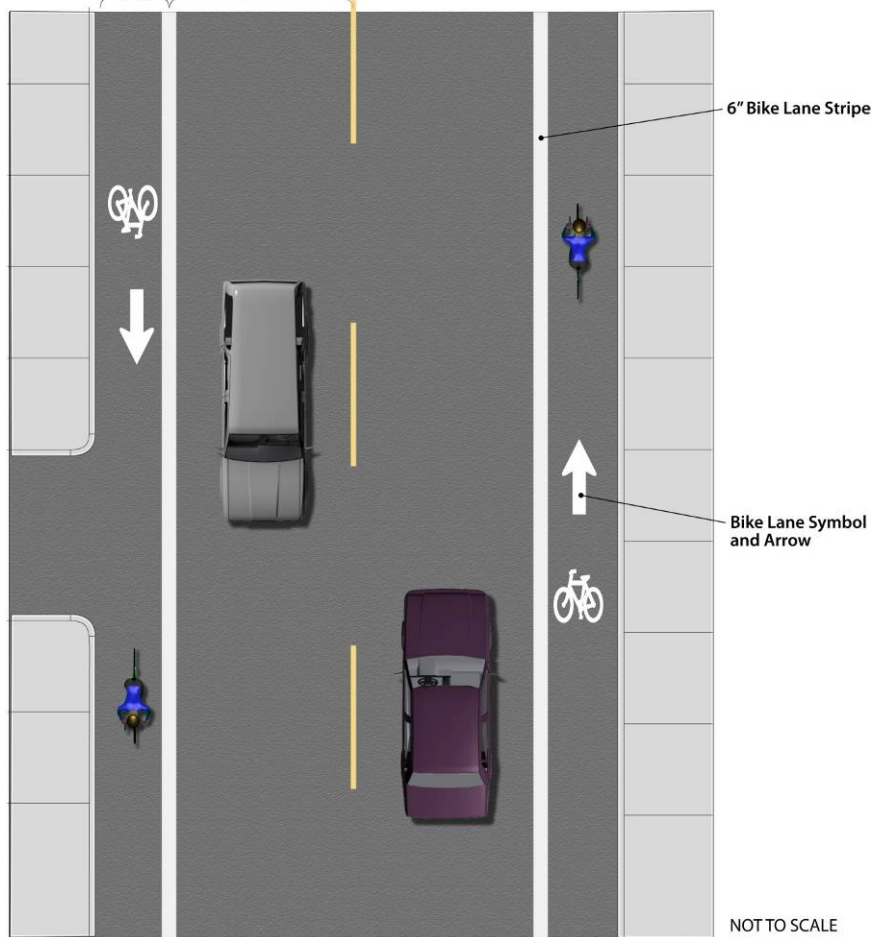
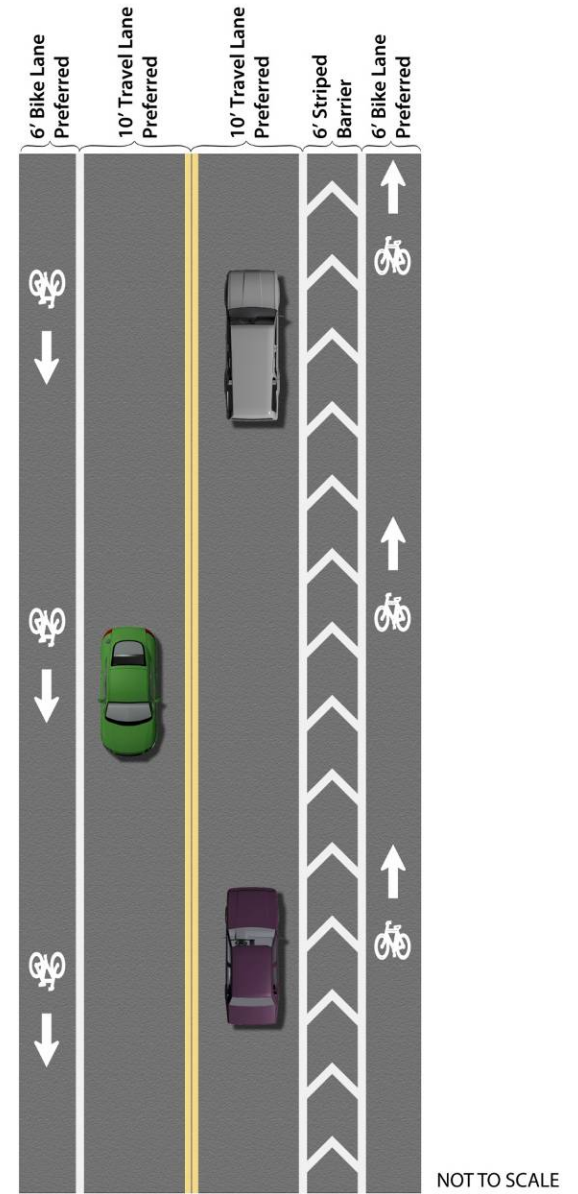


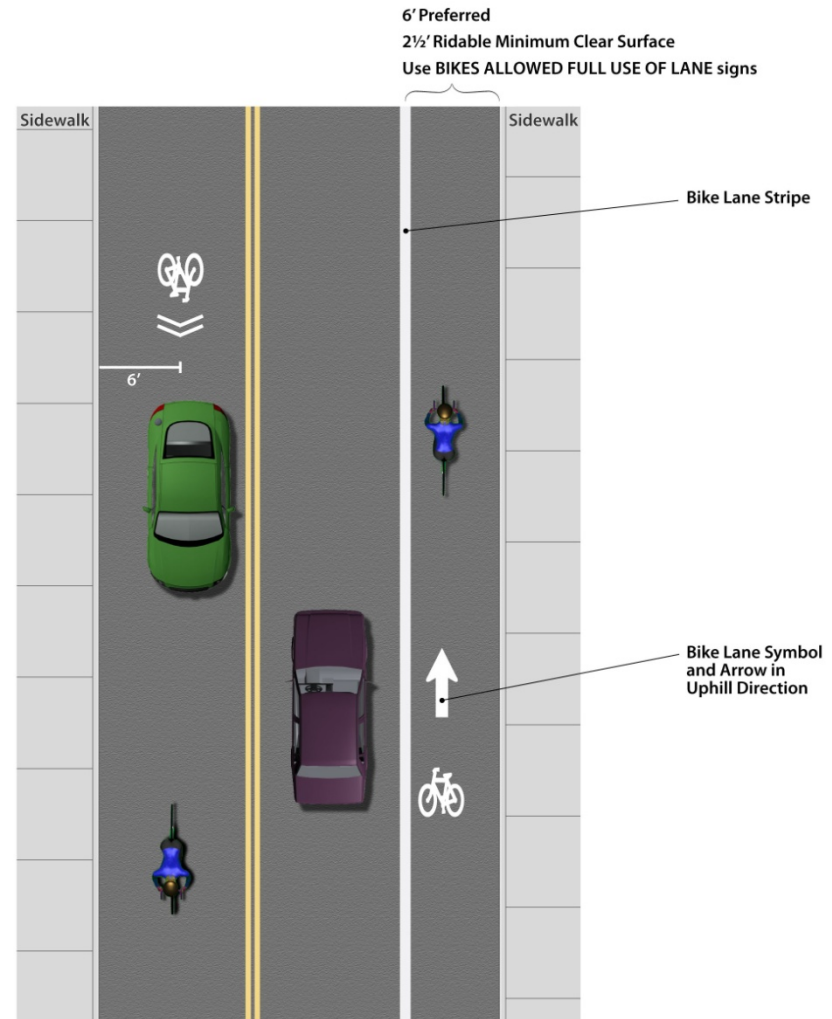
Figure H-6. **Buffered Bicycling Lanes**



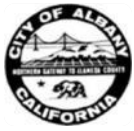
### Bicycling Lanes on Hills

In most cases, bicycling lanes should be provided on both sides of a two-way street; however, in cases where roadways have steep grades, a bicycling lane in the uphill direction and shared lane markings (sharrows) in the downhill direction would be considered acceptable (AASHTO, 2010). On narrower roadways, sharrows may be placed in the center of the lane to discourage vehicles from passing cyclists. BIKES ALLOWED FULL USE OF LANE signage may be appropriate on downhill segments. Posted speed limits of 25 mph or lower are preferred.

Figure H-7. Climbing Lanes



NOT TO SCALE



## Bicycling Lanes at Intersections

Nationally, the majority of collisions between motorists and bicyclists occur at intersections. While design guidance for bicycling lanes acknowledges that intersections are often constrained by the desire for additional turn lanes for autos and allows engineers to drop bicycling lanes at intersections, this practice is not recommended. There are several engineering treatments to significantly reduce conflicts at intersections.

Caltrans provides recommended intersection treatments in Chapter 1000 of the Highway Design Manual including bicycling lane “pockets” and loop detectors. Bicycling lane pockets between right-turn lanes and through lanes should be provided where available lane width allows. Where there is inadequate space for a separate bicycling lane and right-turn lane, the designer should consider the use of a combined lane, shown in the figure on the following page. The City of Eugene, Oregon evaluated this design and concluded that it was easy for cyclists to use. A majority of the cyclists using the facility felt that it was no different from a standard right-turn lane and bicycling lane<sup>2</sup>. An alternate treatment is a sharrow, or “shared right of way” marking, in the through lane adjacent to the right-turn lane.

Figure H-13 shows the appropriate location and use of loop detector stencils at intersections and typical striping and lane configurations for bicycling lanes and loop detectors at a multi-lane intersection

Figure H-12 presents several options for the treatment of Class II lanes approaching intersections with right-turn lanes.

## Bicycling Lane Markings

Pavement stencils should be reflectorized and be capable of maintaining an appropriate skid resistance under rainy or wet conditions to maximize safety for bicyclists. The minimum coefficient of friction should be 0.30. Thermoplastic can meet all of these requirements. It is optimized when the composition has been modified with crushed glass to increase the coefficient of friction and the maximum thickness is no larger than 100 mils (2.5 mm).

The Caltrans standard for placement of bicycling lane stencils states that markings should be on the far side of each intersection and at other locations as desired. Generally, bicycling lane markings should be provided at transition points, particularly where the bicycling lane disappears and reappears, as it transitions from curb side to the left side of the right-turn lane. Otherwise, place them at least every 500 feet or once per block. Symbols shown in the figures are for illustration purposes and should not be used as spacing or placement guidelines

### **On the Horizon: Bicycle Boxes**

*Bicycle boxes are used at signalized intersections to create a dedicated space for cyclists while waiting for a green light. They offer the cyclist a “head start” and allow cyclists to position themselves for various movements (left turns, for instance). They also allow cyclists to avoid conflicts with right-turning vehicles.*

*Bike boxes have been used in New York, Tuscon (AZ), Portland, Eugene, and recently in San Francisco. Bike boxes work best at locations where they are self-enforced, that is, where there is a cyclist in the bike box during the red phase for a majority of the time. Therefore, a good baseline for a bike box would be a location with 90-120 bicycles or more per hour.*



<sup>2</sup> Evaluation of a Combined Bicycling lane/Right Turn Lane in Eugene, Oregon, Federal Highway Administration, 2000

Figure H-8. Bicycling Lanes adjacent to parallel parking and at intersections

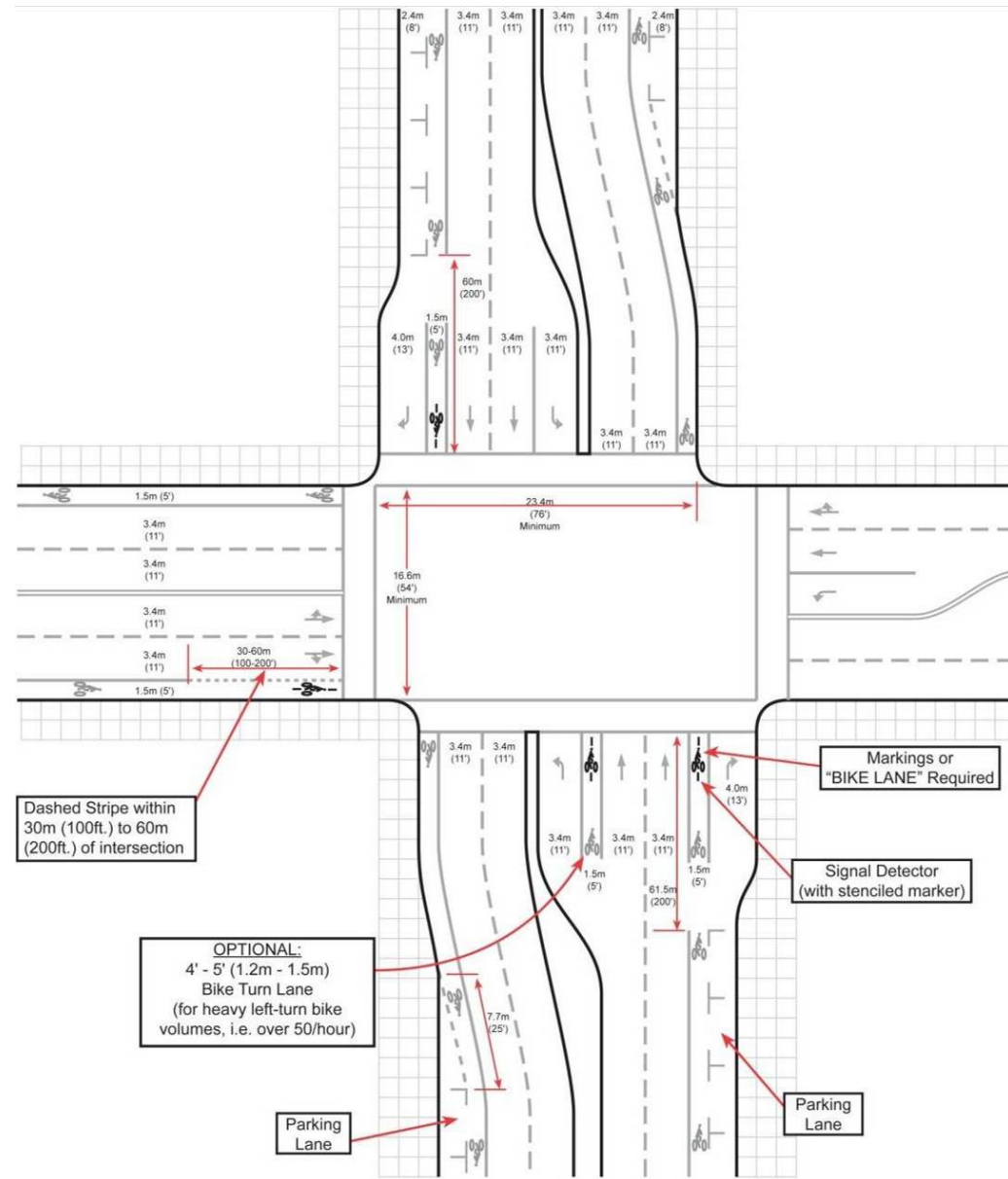
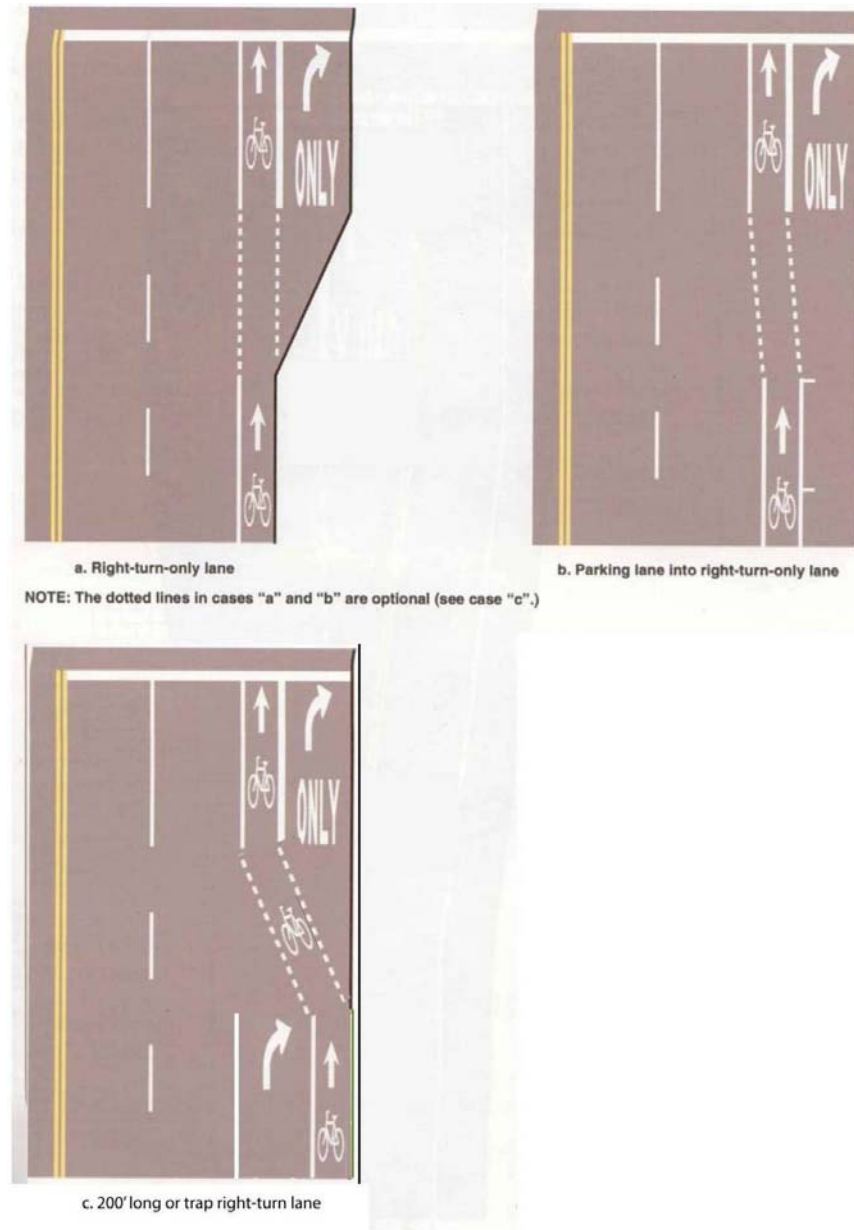






Figure H-9. **Bicycling Lanes at Right Turns**



**Colored Bicycling lanes:** Colored bicycling lanes can be used in high-conflict areas to alert motorists to the presence of bicyclists and bicycling lanes. Cities including Portland, Oregon and New York City have successfully experimented with colored bicycling lanes at highway interchanges and locations where drivers have otherwise encroached on bicycling lanes. These lanes can be painted or treated with thermoplastic. The City of Albany may consider installing a trial colored bicycling lane before expanding the use of the treatment throughout the City. If the City were to use colored bicycling lanes, it should consider requesting formal permission to experiment from the Federal Highway Administration.



**Skip-Stripe:** At intersections with moderate to high bicycle volumes, or at intersections where bicyclists may need to reposition themselves to continue on the bicycling lane, it may be advisable to stripe the bicycling lane through the intersection using dashed lines. This “skip-striping” directs cyclists to the bicycling lane and increases the visibility of cyclists to motorists traveling through the intersection. To identify that the markings are for bicyclists, the City of Albany may consider striping chevrons or sharrows through the intersection as well.





### ***On the Horizon: Separated Bikeways***

*Separated on-street bike lanes provide a buffer between bikes and cars. These facilities are useful along streets with moderate to high bicycle volumes and relatively few driveways or intersections. New York City has recently and extensively used separated on-street bikeways to improve bicycling conditions on several key corridors.*

*The New York Department of Transportation has experimented with two forms of separated bikeways. The first physically separates the bike lane from vehicle traffic and the bike lane is positioned between the sidewalk and the parking lane. At intersections, bikes receive a signal that allows cyclists to proceed without conflicting with turning vehicles. The second treatment positions the bike lane between the travel lane and the parking lane; however, a striped painted median separates the travel lane from the bike lane. The New York Street Design Manual recommends allowing at least 8' of space to accommodate the separated bike lane and the adjacent separation marking or structure.*



*Images: (left) 9<sup>th</sup> Avenue, New York City (RL Layman); (right) Greenwich Street (L Alter)*



### Treatments at Highway Interchanges

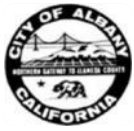
Bicycling and walking routes at highway interchanges require special treatment to ensure the safety and comfort for all road users. Fast moving traffic, highway on and off-ramps and wide travel lanes make interchanges difficult areas for bicyclists and pedestrians to navigate. The guidance below can be used for retrofit projects or new interchange designs. Travel lanes should be reduced from 12 feet to 10 or 11 feet to slow motor vehicle speeds and provide additional space for bicycling lanes and sidewalks.

- Class II bicycling lanes should be striped continuously across overpasses and underpasses wherever feasible
- Minimize distances in which bicyclists are required to travel between two moving traffic lanes
- Use skip stripes to delineate bicycling path travel through conflict zones
- Consider colored bicycling lanes in conflict areas
- Avoid high-speed, uncontrolled movements. A tight diamond configuration with square off and on-ramps to encourage slower motor vehicle speeds and is recommended
- Avoid multiple right-turn lanes on cross-street. Dedicated right turn lanes create a conflict for cyclists traveling through an intersection that must cross the right turn lane to continue to ride straight. Where possible, retain single right-turn lanes, even if greater than 200 feet. Where possible, avoid right-turn lanes greater than 200 feet

### Treatments at Bridges and Tunnels

Bicycling connections to bridges and tunnels require special treatment to ensure the safety and comfort for all road users. Fast moving traffic, transitions between the roadway and the structure and wide travel lanes often make approaches to bridges and tunnels difficult areas for bicyclists and pedestrians to navigate. Appropriate measures to improve bicycling safety at bridge and tunnel approaches include:

- Reduce travel lanes from 12 feet to 10 or 11 feet to slow motor vehicle speeds and provide additional space for bicycling lanes and sidewalks
- Stripe Class II bicycling lanes continuously across bridges and through tunnels wherever feasible
- Minimize distances in which bicyclists are required to travel between two moving traffic lanes
- Use skip stripes to delineate bicycling path travel through conflict zones
- Consider colored bicycling lanes in conflict areas



## Bicycle Loop Detectors and Push Buttons



As new signals are installed or major updates occur to existing signalized locations, bicycle loop detectors should be installed on the bikeway system at the stop bar for all actuated movements of the signal. It is suggested that loop detectors be installed in the approach bicycling lane 100 feet in advance of the intersection as well as at the intersection itself. The upstream loop should not be used when it would be triggered by right-turning vehicles. When the upstream loop is triggered, the green time should be extended for the cyclist to reach the loop at the stop bar, at which point the signal should allow the cyclist to clear the intersection. The time that a bicyclist needs to cross an intersection is longer than the time needed for a motorist, but shorter than the time needed for pedestrians. The AASHTO Guide for the Development of Bicycle Facilities includes detailed equations for bicycle signal timing. In general, while the normal yellow interval is usually adequate for bikes, an adjustment to the minimum green should be considered.

Stencils indicating the loop detector should be marked on the roadway at the intersection where a bicyclist may not be positioned correctly over a loop. The figure on the following page shows the appropriate location and use of loop detector stencils at intersections.

Pushbuttons are appropriate when other methods of detection are not feasible, particularly at narrow tunnels or where multi-use paths cross signalized intersections. A bicycle pushbutton/pad/bar is similar to those used for pedestrians, but installed in a location most convenient for bicycles and actuates a signal timing most appropriate for bicyclists. The sign plate located above the pushbutton/pad/bar indicates that it is for use by bicyclists. The larger the surface of the button, the easier it is for cyclists to use, thus a push pad is preferential to a pushbutton, and a push bar is preferential to a push pad, as it can be actuated without removing one's hands from the handlebars. Advantages of the pushbutton are that it is typically less expensive than other means of detection, and it allows for different signal timing for different user needs. The disadvantages of the pushbutton are that the location of the pushbutton usually does not allow the cyclist to prepare for through or left-turning movements at the intersection, and that it forces the bicyclist to stop completely in order to actuate the signal.

### **Caltrans Policy Directive 09-06**

*Caltrans recently modified its policy on bicycle detection at new and modified approaches to traffic-actuated signals. The California MUTCD was amended to require that in-pavement bike detectors or pushbuttons be placed on approaches to signalized intersections. If more than 50 percent of limit line vehicle detectors need to be replaced, then an entire intersection should be upgraded so that every lane has limit line detection. The signal timing guidance was also updated to reflect a bike speed of 10 mph (14.7 ft/sec) with 6 seconds of startup time based on current research.*

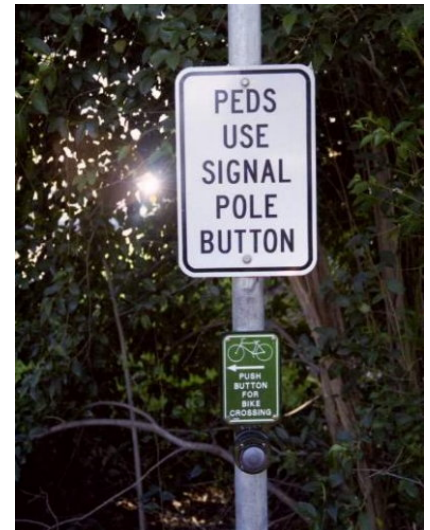
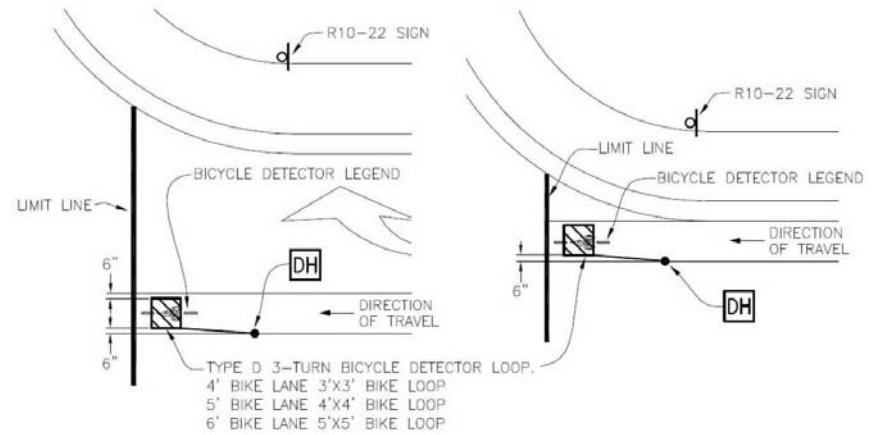


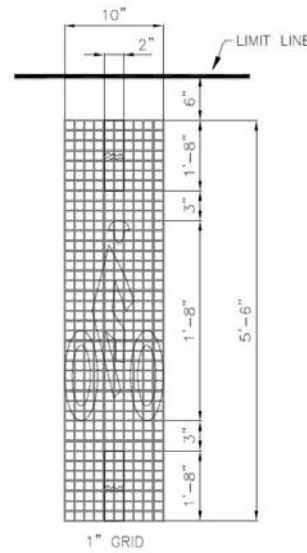
Figure H-10. Bicycle Loop Detector



NOTE: CENTER OF BICYCLE DETECTOR LOOP SHALL BE 3' BACK FROM THE LIMIT LINE.

**TYPICAL BICYCLE DETECTOR LOOP AND LEGEND PLACEMENTS**

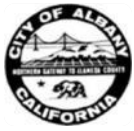
(NO SCALE)



**BICYCLE DETECTOR LEGEND**  
 (NO SCALE)



**R10-22 SIGN**  
 (NO SCALE)



### CLASS III BICYCLING ROUTES

Class III bicycling routes are intended to provide continuity throughout a bikeway network and are primarily identified with signage. Bicycling routes can be used to connect discontinuous segments of a Class I or Class II bikeway. Bicycling routes are shared facilities either with motorists on roadways or with pedestrians on sidewalks (not desirable).

Minimum widths for bicycling routes are not presented in the Highway Design Manual, as the acceptable width is dependent on many factors. The following table presents recommended average daily traffic (ADT) and speed thresholds for bicycling routes.

**Table H-3. Recommended Guidelines for Class III Facilities**

Curb Lane Width (in feet)	Average Daily Traffic (ADT)	Travel Speed
12' (arterial); 11' (collector); no minimum on local street	Under 5,000 vehicles	Under 25 mph
14'	5,000 – 20,000	25 – 35 mph
15'	Over 20,000	Over 35 mph

Source: Fehr & Peers

### Share the Road Markings

Share the Road Markings, or “sharrows” are a newer design application used in California, and have been tentatively approved for the 2009 update to the CA MUTCD Standards. Sharrows are on-street stencils that reinforce that bicyclists are legitimate road users, and are helpful connectors between Class I or Class II facilities when roadway widths are too narrow for a bicycling lane. Sharrows are suitable for streets with posted speeds below 35 mph, preferably with on-street parking.

Another potential application for sharrows is in high-conflict zones. Some cities are experimenting with colored bicycling lanes for this purpose; however, Sharrows are more immediately understood by motorists and cyclists as a bicycling facility. New York is the latest American city to use Sharrows this way, although they have long been used in Paris to raise the visibility of cyclists through complex intersections and to clearly indicate the best path of travel for cyclists.

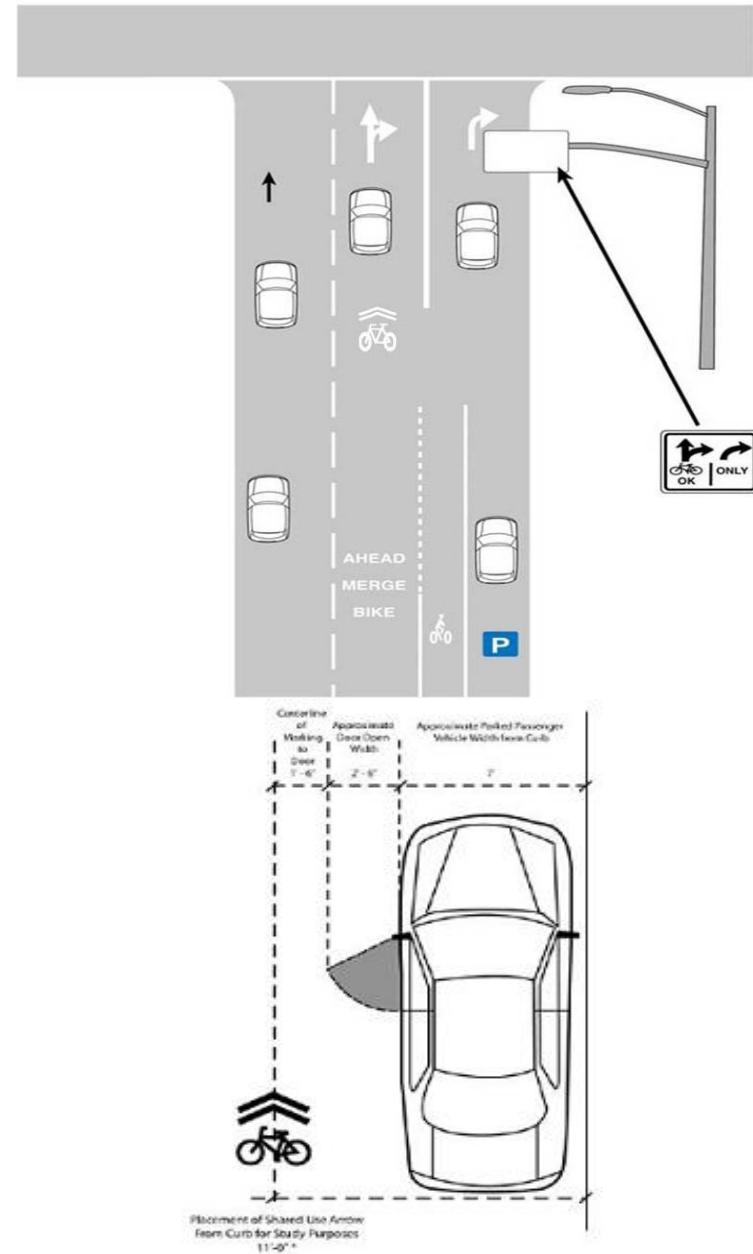
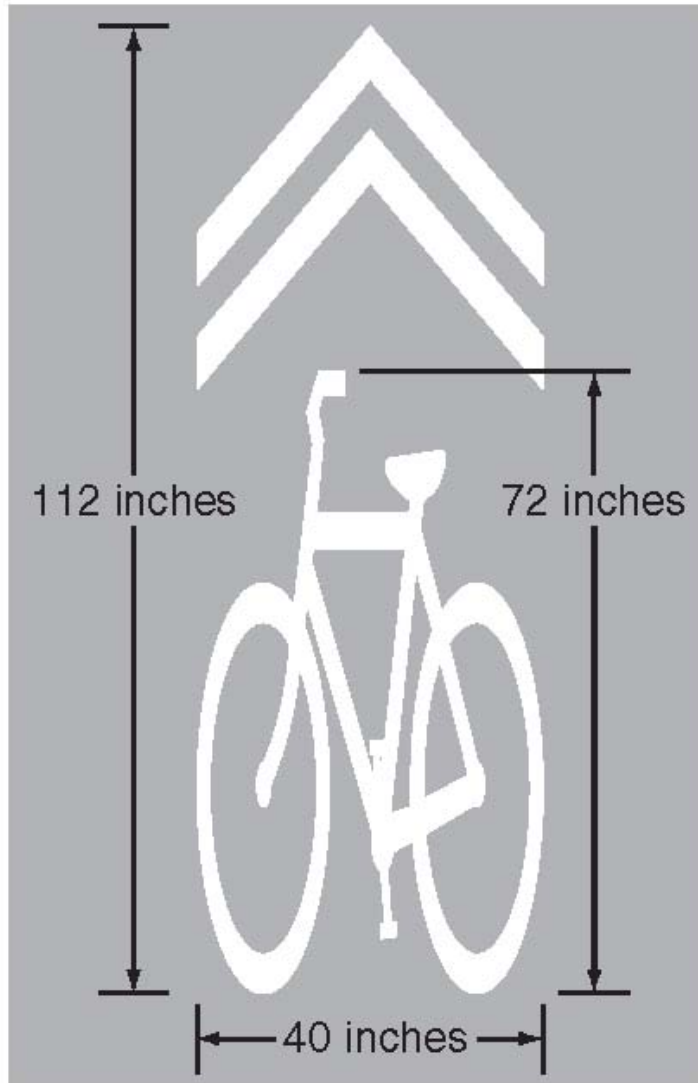
### Guidance for Sharrow Placement (from Section 9C.07 of the 2009 MUTCD)

If used in a shared lane with on-street parallel parking, sharrows should be placed so that the centers of the markings are at least 11 feet from the face of the curb, or from the edge of the pavement where there is no curb.

If used on a street without on-street parking that has an outside travel lane that is less than 14 feet wide, the centers of the Shared Lane Markings should be at least 4 feet from the face of the curb, or from the edge of the pavement where there is no curb. If used, the Shared Lane Marking should be placed immediately after an intersection and spaced at intervals not greater than 250 feet thereafter.

**Optional:** A “BICYCLES MAY USE FULL LANE” sign may be used in addition to the Share the Road Markings to inform road users that bicyclists might occupy the travel lane.

Figure H-11. 2009 MUTCD and Caltrans Shared Roadway Marking Guidance for Installation



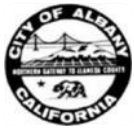
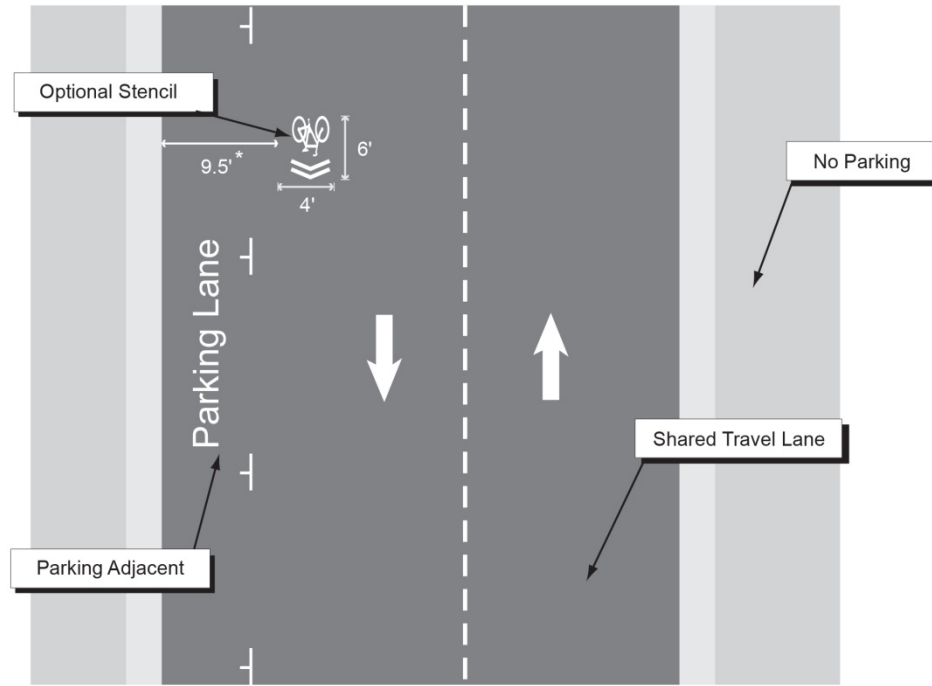


Figure H-12. Typical Class III Bicycling Routes



\* Where travel lane width is 10' or less, place stencil in center of travel lane.

Width Varies  
(See note below)

TYPICAL SIGNING



NOTE:  
Bike route width varies. 14' is desirable for a shared lane.

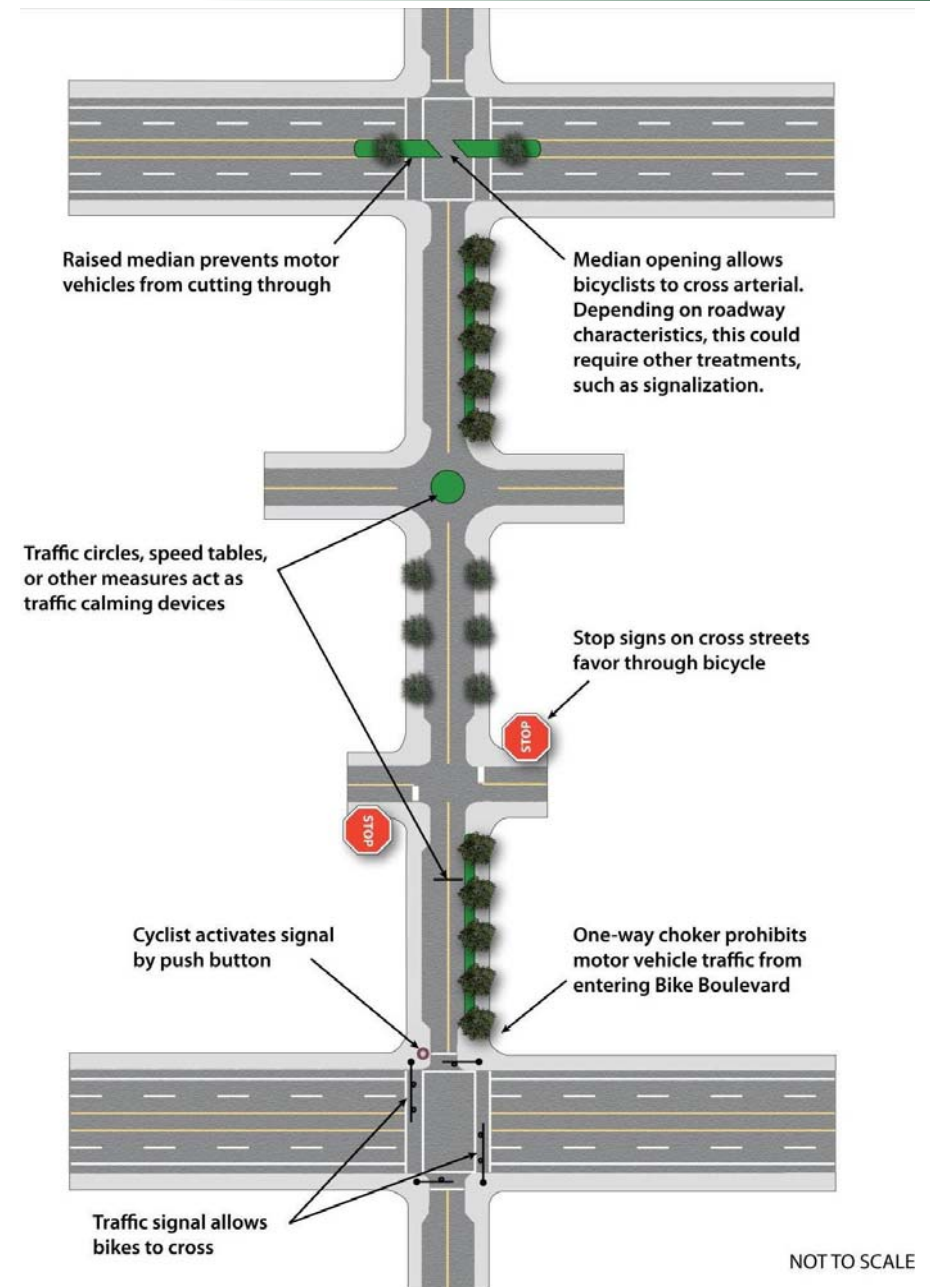
W11-1 / W16-1  
Share the Road with Bicyclists assembly

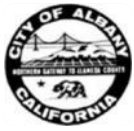


### Bicycling Boulevards

An additional type of Class III facility is the Bicycling Boulevard. Typically, bicycling boulevards are on low-volume streets adjacent to higher volume arterials where bicycles have priority and have a relatively stop-free, low conflict route to their destinations. Traffic calming treatments such as traffic circles, chokers and medians are often used on bicycling boulevards to calm traffic.

There are six general issues to address during bicycling boulevard implementation, as shown in the table below. These issues relate to bicycling and walking safety and traffic circulation. There are two categories of tools that can help address these issues. The first category is called Basic Tools. These strategies are appropriate for all bicycling boulevards. The second category is called Site Specific Tools. These are used to varying degrees on a bicycling boulevard to respond to a specific issue, and they require more analysis and stakeholder involvement.





**Table H-4. Considerations and Tools for Bicycle Boulevards**

Issue	Basic Tool	Site Specific Tools
<ul style="list-style-type: none"> <li>• Create the look and feel of a bicycling boulevard</li> <li>• Slow traffic and discourage diversion of traffic to the bicycling boulevard when unwarranted STOP signs are removed. Unwarranted STOP signs cause excessive stopping and delay for cyclists. They also increase noise and air pollution, increase fuel consumption, and non compliance compromises safety for all. They often increase speeds mid-block as well.</li> <li>• Address school or walking safety issues</li> <li>• Help bicyclists cross major streets</li> <li>• Reduce motor vehicle traffic speeds</li> <li>• Prevent diversion of motor vehicle traffic onto adjacent neighborhood streets</li> </ul>	<ul style="list-style-type: none"> <li>• Signage</li> <li>• Unique pavement stencils</li> <li>• Pavement legends</li> <li>• Landscaping and street trees</li> </ul>	<ul style="list-style-type: none"> <li>• Traffic circles</li> <li>• Curb extensions</li> <li>• Traffic signals</li> <li>• High-visibility crosswalks</li> </ul>

Source: Berkeley Bicycle Boulevard Tools and Design Guidelines



## BICYCLE SIGNAGE

Several new bicycling guide signs, along with information on their use, will be added to the 2009 CA MUTCD guidelines. These signs provide flexibility and may reduce costs for signing bicycling routes in urban areas where multiple routes intersect or overlap.

### Wayfinding and Destination Signage

Among these signs are a new Alternative Bicycle Route guide sign and new Bicycling Destination signs, which indicate direction, distance in miles and destinations along bicycling routes.

In July 2009, the City of Oakland adopted a new system for bicycling wayfinding signage<sup>3</sup> based on these new MUTCD sign standards, with the addition of the City of Oakland logo (see image, right). The City of Albany should consider adopting a similar system, and should consider a logo or City seal that reflects local qualities.

The green sign system includes three sign types:

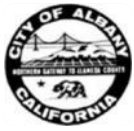
- **Confirmation Signs:** Confirm that a cyclist is on a designated bikeway. Confirmation signs are located mid-block or on the far side of intersections, and include destinations and distances
- **Turn Signs:** Indicate where a bikeway turns from one street on to another street. Turn signs are located on the near side of intersections, and include directional arrows.
- **Decision Signs:** Mark the junction of two or more bikeways. Decision signs are located on the near-side of intersections, and include destinations and directional arrows.

Destination symbols, such as to the El Cerrito and North Berkeley BART Stations, shoreline access, and community destinations may be used. Figure H-13 on the next page illustrates these sign types.



---

<sup>3</sup> The City of Oakland's Design Guidelines for Bicycle Wayfinding Signage can be found at <http://www.oaklandpw.com/AssetFactory.aspx?did=3528>



### Signs for Shared Roadways

**Share the Road Signage:** A “Share the Road” sign assembly (W11-1 + W16-1P) is intended to alert motorists that bicyclists may be encountered and that they should be mindful and respectful of them. However, the sign is not a substitute for appropriate geometric design measures that are needed to accommodate bicyclists. The sign should not be used to address reported operational issues, as the addition of this warning sign will not significantly improve bicycling conditions. The sign may be useful under certain limited conditions, such as at the end of a bicycling lane, or where a shared use path ends and bicyclists must share a lane with traffic. The sign may also be useful during construction operations, when bicyclists may need to share a narrower space than usual on a travelway. This sign should not be used to indicate a bicycling route. A fluorescent yellow-green background can be used for this sign.

Another sign that may be used in shared lane conditions is the BICYCLES MAY USE FULL LANE sign (R4-11). This sign may be used on roadways without bicycling lanes or usable shoulders where travel lanes are too narrow for cyclists and motorists to operate side by side within a lane.

**Wrong Way Riding:** Where wrong way riding by cyclists is a frequent problem, the MUTCD provides a bicycling WRONG WAY sign and RIDE WITH TRAFFIC plaque (R5-1b and R9-3c) that can be mounted back-to-back with other roadway signs (such as parking signs) to reduce sign clutter and minimize visibility to other traffic. This sign assembly can be used in shared lane situations, as well as on streets with bicycling lanes and paved shoulders

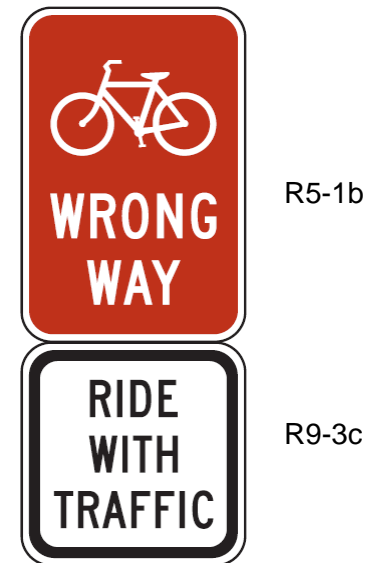
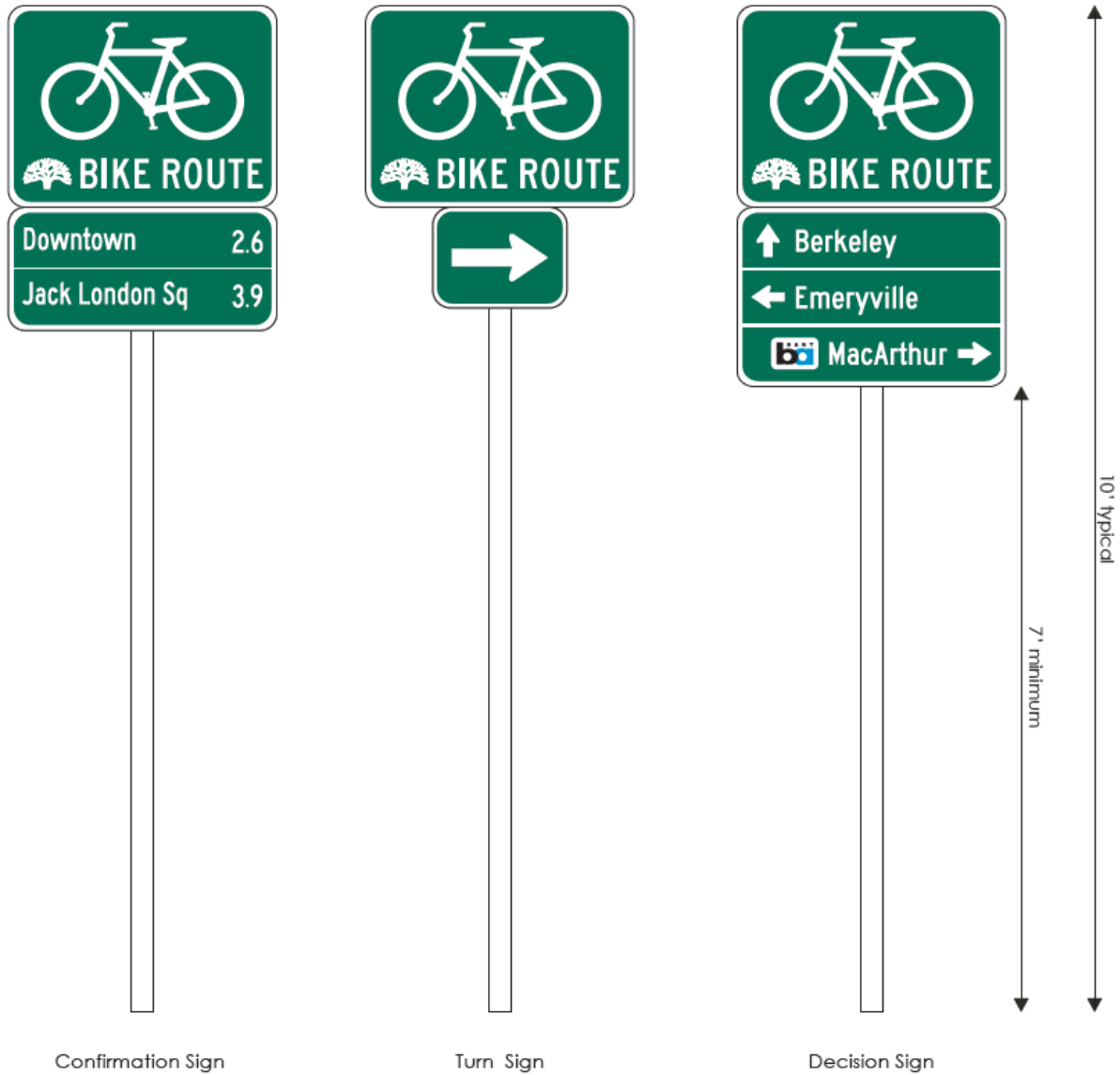


Figure H-13. **Bicycling Sign Types for the City of Oakland** (source: City of Oakland Design Guidelines for Bicycling Wayfinding Signage, July, 2009)





## MAINTENANCE STANDARDS

Since most cycling occurs on public roads, roadway maintenance is an important part of accommodating cycling. Below are some types of targeted maintenance.<sup>4</sup>

**Surface Repairs:** Inspect bikeways and road shoulders regularly for surface irregularities, such as potholes, pavement gaps or ridges. Such hazards should be repaired quickly.

**Sweeping:** Prioritize bicycling routes when establishing a street sweeping schedule. Sweep road shoulders of accumulated sand and gravel in the springtime and fallen leaves in the autumn where they accumulate. Sweepings should be picked up rather than just pushed aside in areas with curbs. Driveway approaches may be paved to reduce loose gravel on paved roadway shoulders. Off-street bicycling facilities should have an established maintenance schedule that includes routine sweeping.

**Pavement Overlays:** Where new pavement is installed, extend the overlay to the edge of the roadway. If this is not possible, ensure that no ridge remains at the edge of the road shoulder or bicycling lane. Do not leave a ridge within the bicycle travel area. Drain grates should be within 6 millimeters of the pavement height to create a smooth travel surface. Special attention should be given to ensure that utility covers and other road hardware are flush with new pavement.

**Rail Crossings:** Rail crossings can be hazardous to cyclists, particularly if they are at an oblique angle. Warning signs and extra space at the road shoulder can allow cyclists to cross at a 90° angle. A special smooth concrete apron or rubber flange may be justified at some crossings.

**Vegetation:** Vegetation may impede sight lines, or roots may break up the travel surface. Vegetation should be cut back to ensure adequate sight lines, and invasive tree roots may be cut back to preserve the travel surface.

**Street Markings:** Bicycling lane markings and signal loop indicators may become hard to see over time. These should be inspected regularly and retraced when necessary.

**Markings:** Whenever roadway markings are used, traction or non-skid paint should be used to avoid the markings becoming slippery in wet weather.

---

<sup>4</sup> Todd Litman, Robin Blair, Bill Demopoulos, Nils Eddy, Anne Fritzel, Danelle Laidlaw, Heath Maddox, and Katherine Forster. *Pedestrian and Bicycle Planning: A Guide to Best Practices*. Victoria Transport Policy Institute (2010)

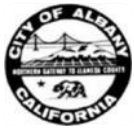
### Utility Covers and Construction Plates

Utility covers and construction plates present obstacles to bicyclists due to their slipperiness and change in surface elevation with the surrounding pavement. While covers and plates can be replaced with less slippery designs, as discussed below, to minimize their adverse impacts on bicyclists, it is best to design the roadway so that they are not located within the typical path of bicyclists riding on the roadway. Therefore, new construction should endeavor not place manhole and other utility plates and covers where bicyclists typically ride (i.e. within the six feet adjacent to the curb, or between 7 and 12.5 feet from curb if parking is permitted). These guidelines require a minimum of 2.5 feet straight and clear.

Wet utility covers and construction plate materials can be slippery. Plain steel plates are slippery and should not be used for permanent installation on the roadway. Temporary installations of construction plates on the roadway should endeavor to avoid using plain steel plates if possible. The placement of construction plates should consider bicycles and if possible, be located to provide a clear zone for cyclists to avoid the plates. An example of an effective method for covers and plates (both steel and concrete) to have acceptable skid resistance is for the manufacturer to imprint waffle shaped patterns or right-angle undulations on the surface. The maximum vertical deviation within the pattern should be 0.25 inch (6 mm).<sup>5</sup>

---

<sup>5</sup> Santa Clara Valley Transportation Authority Bicycle Technical Guidelines



## I. BICYCLE PARKING GUIDANCE

This appendix discusses recommended locations for additional or improved bicycle parking and support facilities.

### Bicycle Parking

Every bicycling trip has two main components: the route selected by the bicyclist and the “end-of-trip” facilities at the destinations, such as safe and secure bicycle parking. This section provides guidance on the provision and placement of bicycle parking facilities.

As the Albany bicycling network grows, so will the population that chooses to ride a bicycle. The availability of secure and convenient parking is as critical to bicyclists as it is for motorists. The availability of short and long-term bicycle parking at key destinations such as parks, schools, community facilities, transit stations, shopping areas and downtown is a vital part of a complete bicycling network.

Parking should be highly visible, accessible and easy to use. Facilities should be located in well-lit areas and covered where possible. Installation is equally important; for example a rack that is too close to a wall or other obstruction will not be effectively utilized. See the figures on the following pages for design specifications.

There are different types of parking facilities just as there are different levels of bikeway facilities. Parking facilities fall into one of three main categories:

#### In-Street/Sidewalk Parking

This section describes several types of typical in-street and sidewalk parking techniques.

#### Inverted U-Racks

Bicycle Racks are low-cost devices that provide a

In-Street / Sidewalk Parking		
<ul style="list-style-type: none"> <li>Inverted U-Rack</li> <li>In-Street Bicycle Corral</li> <li>Covered Bicycle Parking Facilities</li> <li>Surface Parking Lot Conversion</li> </ul>	Appropriate in areas with pedestrian activity and commercial areas. In-street facilities are ideal for areas with constrained sidewalk space.	Ideal for short-term parking needs (2-3 hours)
Lockers		
<ul style="list-style-type: none"> <li>Key Lockers</li> <li>Electronic Lockers</li> </ul>	Appropriate for areas with low street activity or isolated areas.	Provides a high level of security, useful for long-term parking needs (>3 hours)
Enclosed Facilities		
<ul style="list-style-type: none"> <li>Bicycle Cage</li> <li>Bicycle Room</li> <li>Bicycle Station</li> </ul>	Ideal for major transit hubs and areas with high bicycle volumes. Enclosed facilities can also be located in residential, commercial or employment centers with indoor space.	Provides the highest level of security, particularly when parking is attended. Ideal for long-term and over-night parking needs.



Image I-1: Inverted U-Rack



location to secure a bicycle. Ideally, bicyclists can lock both their frame and wheels. The bicycle rack should be in a highly visible location secured to the ground, preferably within 50 feet of a main entrance to a building or facility. Whenever possible, the racks should be visible from the doorways and/or windows of buildings, and not in an out of the way location, such as an alley. Short-term bicycle parking is commonly used for short trips, when cyclists are planning to leave their bicycles for a few hours.

The most common mistake in installing bicycle racks is placing them too close to a wall or fence, or orienting them the wrong way, rendering the rack unusable; nor should they impede pedestrians. In addition, in order to accommodate a range of bicycle styles and sizes, racks must be installed to allow sufficient space between bicycles and between racks.

If there is space for two or more bikes on a single rack, it is recommended to provide 36 inches (30 inches minimum) center to center between bicycle tires when bicycles are locked side to side; otherwise, the handlebars of one bicycle can prevent another bicycle from parking in the adjacent space.

In addition to optimizing space by situating adjacent bicycles a sufficient distance apart, bicycle racks must be installed to allow sufficient space for bicyclists and their bicycles to move about between racks. In most cases, a standard bicycle footprint is six feet long. Aisles between rows of racks must be a minimum of four feet wide.

### Other Considerations

- There are two primary types of rack installation: surface mount and cast-in place. Surface mount is preferred; however racks are designed for only one or the other installation type. In all cases, racks should be installed in concrete, never in soil and rarely in asphalt. There are issues to consider with each type of installation, detailed below:
- **Surface mount:** for installation after the substrate is in place (e.g. concrete slabs). For many rack types, this is the only option, but care should be taken in choosing the installation hardware. A technique among bicycle thieves is to steal a whole rack and load it into a truck, so only anti-tampering bolts and other hardware should be used. Surface mounted bicycle racks should only be mounted in concrete – asphalt will not securely hold the mounting hardware. If an asphalt substrate is all that is available, concrete footings should be poured. Multiple loop racks on flanges may be installed in asphalt, which can be useful for in-street bicycle corrals. For a more secure rack

### Bicycle Rack Materials & Coatings

There are a variety of materials and coatings available for steel bicycle racks. Individual choices may vary depending on the available budget and aesthetic preferences, but the main options include the following:

- **Stainless Steel** is the recommended choice because it is attractive and relatively maintenance free, but it is also typically the most expensive.
- **Galvanized Coatings** are durable and much cheaper than stainless steel, but galvanized racks are not typically considered as attractive as other options. The low price and easy maintenance makes galvanized racks one of the most popular options.
- **Vinyl Coating** is a good option when aesthetics and durability are considered. Vinyl requires minimal maintenance. More importantly, vinyl coatings are the most user-friendly of all the options because they will not scratch bicycles the way harder coatings will.
- **Powder Coating** provides the best color coating option and is highly durable. It is more resistant to wear than regular paint and can easily be touched up if needed. Powder coating is usually the same cost as galvanized.
- **Paint** is not as durable as some of the other options. This is a major issue in areas where metal surfaces are subjected to alternating cycles of large amounts of rain in the winter months and searing heat in the summer. Paint chips, wears off quickly and requires regular repainting and maintenance to keep a reasonable appearance.

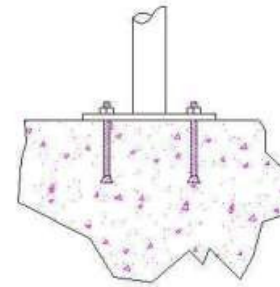


Image I-2: Surface mount bicycle rack installation

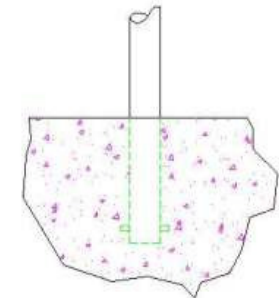


Image I-3: Embedded Bicycle rack installation, also known as “cast-in-place” (courtesy of Creative Metalworks)



installation, perpendicular bars could be installed under the surface to prevent the rack from being pulled directly from the concrete. See Image I-2.

**Embedded or cast-in-place:** consider whether the location where the rack needs to be installed may already have a slab poured, or the chosen rack type may not provide a cast-in-place option. Also, embedded racks are expensive to relocate in the future if needed. Cast-in-place installation is appropriate for asphalt or concrete. See Image I-3.

- **Bicycle Spacing:** The basic footprint of bicycle parking design, whether parked horizontal or vertical, is 6 feet long, 2 feet wide, and 4 feet high. There are also spatial parameters to consider, and some rack makers do not allow enough space between the racks to allow for handlebar widths. The following specifications for inverted U-racks provide guidance on the minimum space needed. Where possible, provide additional spacing.
- **Spacing between Bicycles:** If two or more rack spaces are joined together, there must be a minimum of 30 inches center-to-center between bicycle tires when bicycles are locked side to side, and 36 inches is recommended where more space is available. Otherwise, handlebars can get tangled up – a situation that is especially critical when dealing with large volumes of bicycles with relatively high turn-over of parking.
- **Spacing between Racks:** Aside from the physical space requirements between bicycles on the racks, space must be made for bicycles to move about between racks. If an aisle must be made between bicycle racks, a minimum of two feet wide and six feet long with a three foot aisle must be set aside to allow room for bicycles to move in and out of the racks. Spacing between racks or between a rack and other fixed objects can still be an issue. For most types of bicycles, six feet is considered a standard footprint. The graphics on the following page show typical dimensions and placement requirements for bicycle parking racks. This type of rack can be installed in multiples to provide additional bicycle parking.
- **Artistic Bike Racks:** These bike racks may be considered at some locations, such as schools, public buildings, and parks. Other locations may qualify pending review of the Arts Committee. San Francisco, Spokane, and New York have been using artistic bike racks to give a different character to a specific area. The design of these bike racks should comply with the recommended guidelines provided in this Appendix.



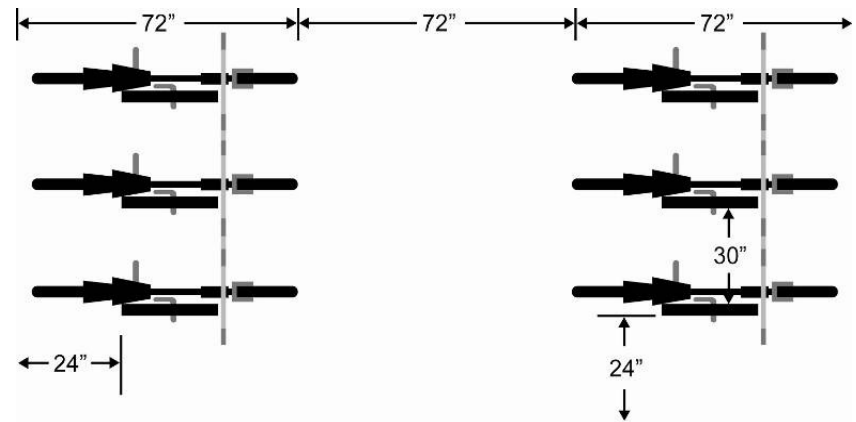
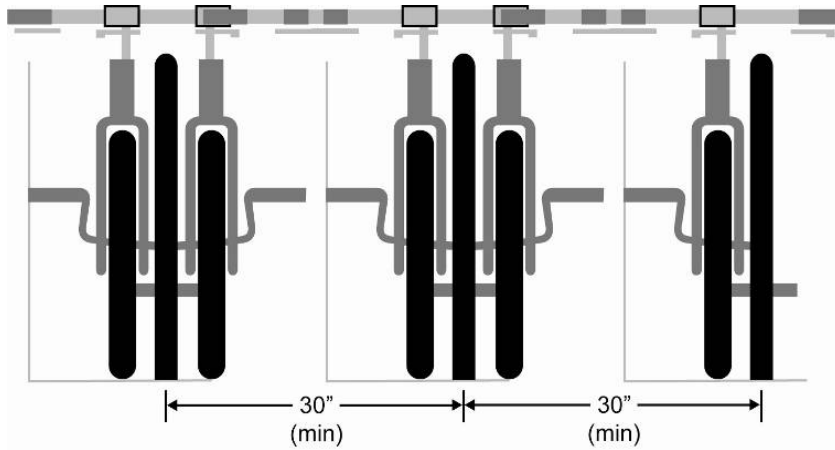
Image I-4: "Wheel bender" bicycle rack



Image I-5: Poor rack design

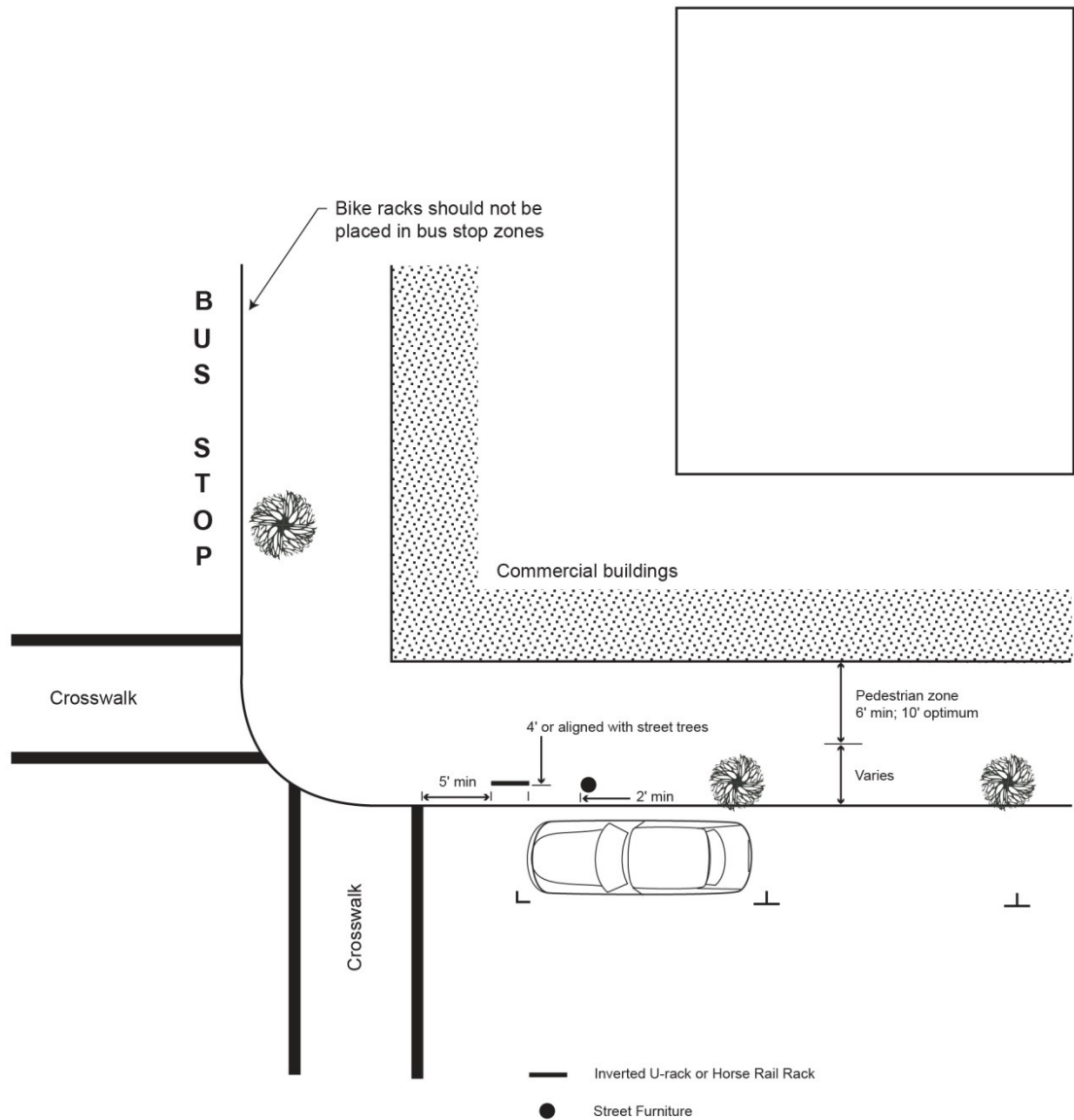


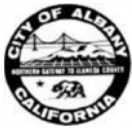
Figure I-1. Recommended Bicycle Rack Spacing (Association of Pedestrian and Bicycle Professionals)



All dimensions are recommended minimums.

Figure I-2. Bicycle Parking on Sidewalks





### In-Street Bicycle Corral

This option is ideal for locations with a high parking demand and insufficient sidewalk space. Bicycle corrals have been used in Portland, San Francisco and Berkeley and involve replacement of parking spaces with inverted U-racks (shown in Image I-6). Bollard installation is recommended to protect cyclists and bicycles from adjacent vehicles. Two vehicle parking spaces can accommodate a corral with 10-12 racks for 20-24 bikes. Costs vary depending on the choice of materials, but can range from \$3,000 for a multiple loop rack and flexible bollards, to \$45,000 for a poured concrete pad, stainless steel bollards and custom racks. Corrals are a relatively low-cost option that reduce sidewalk clutter and do not obstruct the public right-of-way. Corrals can be placed in red zones, but frequently vehicle parking may be removed. If parking is a priority in a given area, local jurisdictions should decide whether bicycle corrals are appropriate.

### Covered Facilities

Covered bicycle racks, also referred to as a “bicycle oasis” provide shelter from weather conditions, constant rain in the winter takes its toll on bicycles causing a bicycle’s metal frames to rust, but constant sunlight all summer can be worse with ultraviolet rays deteriorating seats and tires. Covered bicycle parking has also been proven to increase cyclists’ willingness to park their bicycles for longer periods of time. In order to provide secure coverage from rainfall and clearance for cyclists, the cover should be at least seven feet above the ground. Existing covers such as overhangs or awnings are a low cost way of incorporating covered parking.

New York City and Portland have begun to implement covered bicycle parking. These designs provide shelter, maps, and advertisement capabilities (see Image I-7). Covered racks do not necessarily deter theft any more than uncovered racks, and partial cover or cover that is too high does not protect against weather conditions and thus defeats the purpose.



Image I-6: In-street bicycle corral



Image I-7: Covered bicycle facility

### Surface Parking Lot Conversion

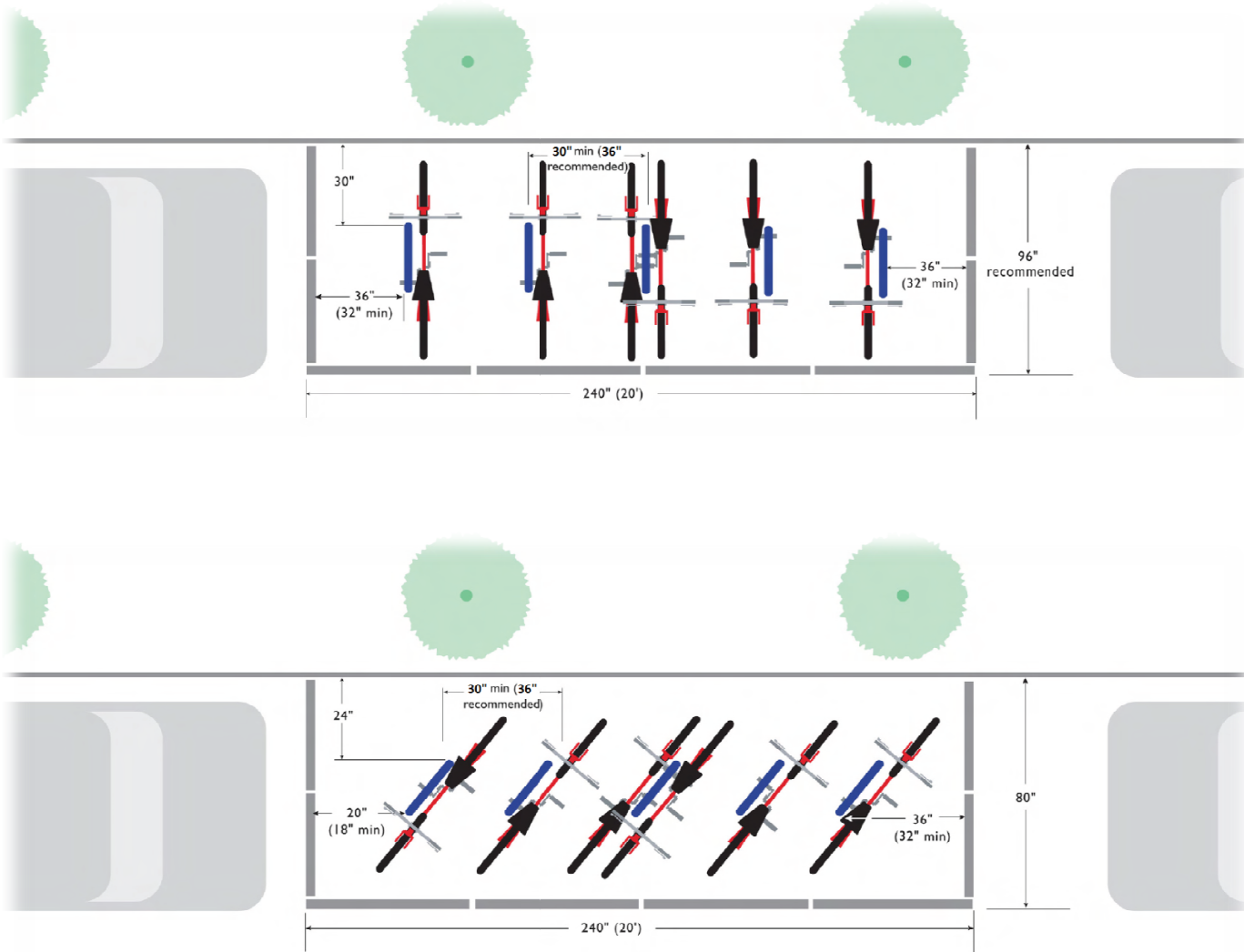
Parking lots near key destinations are ideal places for converting a few parking spaces into short term or long-term bicycle parking. Five to six racks can fit into the space occupied by one car (as shown in Image I-8). Adding U-racks with bollards and a covered or fenced area designates bicycle parking from vehicle parking. Bicycle cages (see Image I-11) can also be used in parking lots and provide security access through electric pass key systems. Simpler, less expensive modifications of surface lot parking spaces, such as a bicycle corral may be considered.



Image I-8: Surface parking lot conversion, CPMC – Davies Campus



Figure I-3. Bicycle Parking Lay-out for an In-street Parking Space





### Bicycle Lockers

Bicycle Lockers are covered storage units that can be locked individually, providing secure parking for one bicycle. Bicycle cages are secure areas with limited-access doors. Occasionally, they are attended. Each of these means is designed to provide bicyclists with a high level of security so that they feel comfortable leaving their bicycles for long periods of time. They are appropriate for employees of large buildings and at transit stations. Lockers provide a secure place for bicyclists to store their helmets or other riding gear. Showers are important for bicycling commuters with a rigorous commute and/or formal office attire.

### Electronic Lockers

Electronic bicycle lockers provide secure individualized parking that can be accessed with an electronic card. Unlike standard key lockers, which provide one key for one renter, a single e-locker can be rented by multiple cyclists each week by using smart card technology. The improved efficiency translates into greater availability, and is a popular option at transit stations throughout the Bay Area.

Bicycle lockers come in a variety of shapes and sizes depending on the need and the amount of space available. The most common bicycle locker size is approximately 40" wide by 48" high by 72" long. These typically have a diagonal divider inside the locker so that they will accommodate two bikes. Lockers with diagonal dividers are designed to open from two sides, so there should be adequate room on both sides of the locker to comfortably open the door and slide the bicycle in and out, which equates to six feet of clearance from both doors (see Image I-9 and Figure I-4).

Wedge-shaped locker units accommodate one bicycle, and are a useful design for corner areas. They can also be placed against walls in areas with a constrained public right-of-way.



Image I-9: 19<sup>th</sup> Street & Broadway Downtown Oakland BART (photo by Jason Patton, City of Oakland)

### Bicycle Locker Materials

- **Stainless Steel** is the best material because it is the strongest and most durable, it reflects sunlight well, and requires the least amount of maintenance because stainless steel never needs painting. Increasingly, perforated panels are being used for security purposes to make the contents of the locker visible. Perforated panels reduce the weather protection of the locker, and the top of the locker should always be solid. Also, consider placing perforated lockers in areas less exposed to the elements.
- **Powder Coated Steel** is the second best option. Although not as durable as stainless steel, powder coat will last many years and gives the purchaser a broad range of color options (note: dark colors should be avoided due to heat absorption in the summer.)
- **Composite Materials** such as resin based materials, chip-board, and particle board should be avoided. These materials photo-oxidize and break down quickly, and are easier to break into than steel lockers. However, lockers made of non-metallic sheet molding composites, such as the Cycle-Safe brand, are achieving new levels of quality, performance and cost-effectiveness.

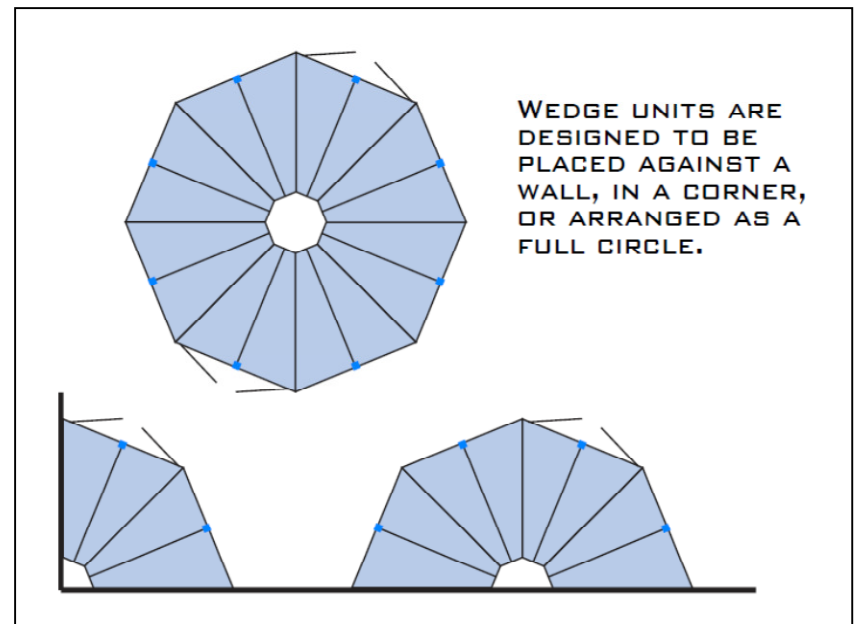
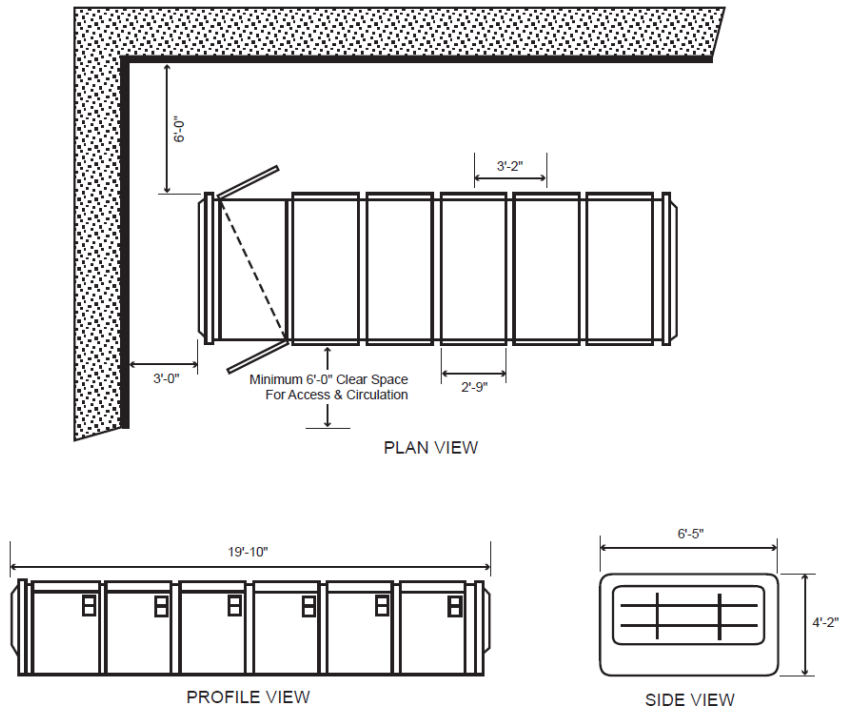


Image I-10: Wedge-shaped lockers



Figure I-4. Bicycle Locker Placement Guidance





## Enclosed Facilities

This section describes several types of typical off-street and enclosed parking facilities.

### Bicycle Cage

Bicycle cages are shared access storage areas in which cyclists lock their own bikes. Bicycle cages are often used by transit centers and large employers or universities to provide an extra layer of security for long-term bicycle parking. Cages are a popular option for bicycle commuters because they provide a high degree of security and they protect bikes. Bicycle cages can be accessed by registered users at any time, and with unlimited ins and outs.

While cages provide additional security over U-racks or other on-street parking facilities, many people may have access to the facility. Small cages are preferred to limit the number of people with access to any single cage. Security may be bolstered by surveillance cameras and monitoring. A single cage of 18' by 20' occupies the same footprint as two standard parking stalls (or 9' by 20' each.)

Cyclists gain access to the bicycle cage by signing up in advance for a key or a key code. Historically, bicycle cages have used conventional lock-and-key systems, but these have proved cumbersome from an administrative standpoint. Magnetic pass keys also allow parking managers to monitor who goes in and out of the bicycle cages. Local jurisdictions or local non-profit organizations are typically responsible for implementing and maintaining this type of facility.

### Bicycle Rooms

Bicycle rooms provide enclosed and sheltered parking and protection from theft. A bicycle room is an excellent option for a transit terminal, but any available building floor space can be converted into a bicycle room. Bicycle rooms may have wall racks or floor racks, and should allow easy access by elevator or ramp to the ground level. Adding self-serve features such as bicycle pumps, bicycle stands and basic tools creates extra amenities for cyclists. They also require little maintenance and an attendant is not needed because users are provided with an access code to enter the facility.

Bicycle rooms are ideal in business parks or apartment or condominium complexes. Individual businesses or apartment complexes would be responsible for providing bicycle room facilities.

### Bicycle Station

The ultimate safety and security option for bicycle commuters and their bikes is the bicycle station, which combines all the safety features of good racks, the security of a bicycle cage, and attended parking; typically only the staff person may check bikes in and out. Users may or may not have to pre-register. In addition to high security bicycle parking, most bicycle stations



Image I-11: High security bicycle cages



also sell basic bicycle accessories, some sell bikes, and the majority provide basic bicycle repair while the cyclist is at work. These extra repair and retail services generate revenue to offset staffing costs and provide additional services for users. All of these options provide further incentives for cyclists to leave their bikes at the station. However, the hours of operation can be limited by funding constraints. Cyclists who want to retrieve their parked bicycle after hours can only do so by prior arrangement with the staff operator. There is usually no charge for regular day or overnight parking in the first few years of operation, since there are usually grant subsidies for operations. Bicycle stations would be appropriate at major transit hubs such as a ferry terminal.

Bicycle stations have high capital and operating costs and may not be feasible unless co-located with other attractors such as major transit hubs, high-density housing and retail. A short- to medium-range improvement for bicycle parking would be unstaffed high capacity bicycle cage(s). Major bus stops and park and ride areas in Albany may be candidate locations for a bicycle station.



Image I-12: Bicycle Station at 4<sup>th</sup> & King Caltrain Station, San Francisco

### **Public Bicycle Parking**

Albany's schools, parks, public buildings and private developments use a variety of rack types, some acceptable and some obsolete:

- Albany High School: Wave (ribbon)
- MacGregor High School: Comb (ladder) [obsolete] and wheel-holder [obsolete]
- Albany Middle School: Wave (ribbon) in fenced area
- Cornell Elementary: Inverted U
- Ocean View Elementary: 2-sided "hanging-triangle" (Urban Accessories Model E)
- Marin Elementary: Comb (ladder) and wheel-holder
- Ocean View Park: Comb (ladder)
- City Hall complex: Wave (ribbon)
- Library / Community Center: Wave (ribbon)
- Target: Post and ring
- PetSmart: Wave (ribbon)
- USDA: Hanging-triangle and wheel-holder

The wave racks at the schools, Library, and City Hall are usable. However, the inverted Us or a series of inverted U racks are preferred. In some locations, such as at Albany High School and the Library, reorienting or rotating wave racks to facilitate two-sided access would improve usability. Many racks on Solano and San Pablo are oriented incorrectly, so bikes parked correctly extend over curb and onto street and/or too far onto sidewalk. Many rack locations were also chosen randomly (i.e. not in front of businesses needing them, in empty areas). Rack locations should be chosen based upon where they will be used, not solely upon distance from other racks. Where possible, racks should be installed under an overhang or roof, to protect bicycles from rain.

There are bike racks that could be considered public art like the ones used in some museums in San Francisco, and other cities like New York and Spokane (see photos on next page). The City of Albany may consider the use of artistic bike racks as long as the design complies with the specifications presented in the Design Guidelines section of this document.



Image I-13: Artistic bicycle rack in Spokane, Washington (photo courtesy of Amy Smolens)



Image I-14: Artistic bicycle rack outside of the American Steel Building (photo courtesy of BikeParking.com)

Albany should consider upgrading existing deficient racks and installing new racks as requested and as development occurs. Large employers (with over 50 employees) should be required to provide adequate bicycle parking, preferably indoor for their employees. **As an action item, the City should adopt an ordinance that states that bicycle racks be installed as a condition of approval for certain land uses.**

#### ***Proposed facilities for changing and storing clothes and equipment***

Especially in Albany's mild weather, bicyclists who commute short distances typically ride in street clothes and do not need to change clothes at work. Because bicycling is approximately four times more efficient than walking, trips of up to four miles (20 minutes) can easily be made in street clothes, depending on temperature and effort.

Bicyclists who ride a longer distance or who commute during hot weather may prefer to change clothes upon arrival. Some may also use a shower if one is available, but not all who change clothes need to shower. For this reason, a secure – ideally, individual -- place to store clothing is a more important commuter amenity than showers, though showers also serve non-bike-commuting employees who exercise at lunchtime or after work.

Commuter clothing storage can take several forms:

- A hanger or garment bag behind a door, if the employee has a closed-door office
- A full-height or half-height clothing storage locker located in a changing area or restroom, assignable long-term to the commuter.
- A locked wardrobe cabinet shared by a small, mutually-trustworthy group of commuters



Image I-15: Half-height (36") lockers



Image I-16: Wardrobe cabinet

Clothing lockers should comfortably accommodate clothes on hangers:

- Depth: 18" to accommodate jackets and shirts on hangers.
- Width: 12" minimum, 15" suggested
- Height: at least 36" for half-height units, to accommodate folded slacks on hangers.  
In larger installations, provide several full-height units for dresses

Albany has few major employers, including the USDA research center, Target, PetSmart, City Hall, and the school district; only the Fire Department has showers and clothing storage for employees.

Recommendation for shower and clothing storage requirement

Albany should consider a Municipal Code requiring employee shower facilities in new buildings and additions based on square footage, with no shower required below a certain area based on building use. For example,

18.16.060 Development Standards

....

(j) Employee Showers



Employee shower facilities shall be provided for any new building constructed or for any addition to or enlargement of any existing building as specified in Table I-1.

**TABLE I-1: EMPLOYEE SHOWERS REQUIRED**

Uses	Gross Floor Area of New Construction (ft <sup>2</sup> )	Showers Required
Medical, Professional, and General Business Offices, Financial Services, Business and Trade Schools, General Business Services	0-9,999	No requirement
	10,000-19,999	1
	20,000-49,999	2
	50,000 and up	4
Retail Services, Personal Services, and Eating and Drinking Services	0-24,999	No requirement
	25,000-49,999	1
	50,000-99,999	2
	100,000 and up	4

Commuter clothing storage should be provided within any employee changing area. If an employee restroom is the only available changing “facility”, one or more clothing storage lockers – possibly half-height -- can often be accommodated while meeting ADA access requirements.

General bike parking code by land use

The following code is based on the “Sample Bicycle Parking Requirements” section in Bicycle Parking Guidelines, 2nd Edition, published in 2010 by the Association of Pedestrian and Bicycle Professionals (APBP / [www.apbp.org](http://www.apbp.org)). In that publication, Chapter 3: Policies, Requirements and Codes contains details for establishing bicycle parking and storage requirements tied to land use, with samples for ordinary and urbanized / high mode share areas. Albany is both urbanized and on its way to a relatively high bicycle mode share. The city’s current 4% is four times the state average and twice the Alameda County rate, and this plan envisions a tripling to 12% by 2020. For these reasons the ratios and numbers in Table I-2 are drawn from the “Urbanized or High Mode Share Areas” sample code.

**TABLE I-2: BICYCLE PARKING REQUIREMENTS**

**Residential**

<b>Type of Activity</b>	<b>Long-term Bicycle Parking Requirement</b>	<b>Short-term Bicycle Parking Requirement</b>
Single Family Dwelling	No spaces required.	No spaces required.
Multifamily Dwelling		
a) With private garage for each unit*	No spaces required	0.10 spaces for each bedroom. Minimum is 2 spaces.
b) Without private garage for each unit	0.5 spaces for each bedroom. Minimum is 2 spaces.	0.10 spaces for each bedroom. Minimum is 2 spaces.
c) Senior Housing	0.5 spaces for each bedroom. Minimum is 2 spaces.	0.10 spaces for each bedroom. Minimum is 2 spaces.

\*A private locked storage unit may be considered as a private garage if a bicycle can fit into it.



**TABLE I-2: BICYCLE PARKING REQUIREMENTS, CONTINUED**

**Civic: Cultural/Recreational**

<b>Type of Activity</b>	<b>Long-term Bicycle Parking Requirement</b>	<b>Short-term Bicycle Parking Requirement</b>
Non-assembly cultural (library, government buildings, etc.)	1.5 spaces for each 10 employees. Minimum requirement is 2 spaces.	1 space for each 8,000 s.f. of floor area. Minimum requirement is 2 spaces.
Assembly (churches, theaters, stadiums, parks, beaches, etc.)	1.5 spaces for each 20 employees. Minimum requirement is 2 spaces.	Spaces for 5% of maximum expected daily attendance.
Health care/hospitals	1.5 spaces for each 20 employees or 1 space for each 50,000 s.f. of floor area, whichever is greater. Minimum requirement is 2 spaces.	1 space for each 20,000 s.f. of floor area. Minimum is 2 spaces.
Education		
a) Public, parochial, and private nursery schools, kindergartens, and elementary schools (1-3)	1.5 spaces for each 20 employees. Minimum requirement is 2 spaces.	1 space for each 20 students of planned capacity. Minimum requirement is 2 spaces.
b) Public, parochial, and private nursery schools, kindergartens, and elementary schools (1-3)	1.5 spaces for each 10 employees. Minimum requirement is 2 spaces.	1.5 spaces for each 20 students of planned capacity. Minimum requirement is 2 spaces.
c) Public and, parochial elementary schools (4-6), junior high and high schools	1.5 spaces for each 10 employees plus 1.5 spaces for each 20 students of planned capacity. Minimum requirement is 2 spaces.	1.5 spaces for each 20 students of planned capacity. Minimum requirement is 2 spaces.
d) Colleges and universities	1.5 spaces for each 10 employees plus 1 space for each 10 students of planned capacity; or 1 space for each 20,000 s.f. of floor area, whichever is greater.	1 space for each 10 students of planned capacity. Minimum requirement is 2 spaces.
Rail/bus terminals and stations/airports	Spaces for 7% of projected a.m. peak period daily ridership	Spaces for 2% of projected a.m. peak period daily ridership



TABLE I-2: BICYCLE PARKING REQUIREMENTS, CONTINUED

**Commercial**

Type of Activity	Long-term Bicycle Parking Requirement	Short-term Bicycle Parking Requirement
Retail		
General food sales or groceries	1 space for each 10,000 s.f. of floor area. Minimum requirement is 2 spaces.	1 space for each 2,000 s.f. of floor area. Minimum requirement is 2 spaces.
General retail	1 space for each 10,000 s.f. of floor area. Minimum requirement is 2 spaces.	1 space for each 5,000 s.f. of floor area. Minimum requirement is 2 spaces.
Office	1 space for each 10,000 s.f. of floor area. Minimum requirement is 2 spaces.	1 space for each 20,000 s.f. of floor area. Minimum requirement is 2 spaces.
Auto Related		
Automotive sales, rental, and delivery Automotive servicing Automotive repair and cleaning	1 space for each 10,000 s.f. of floor area. Minimum requirement is 2 spaces.	1 space for each 20,000 s.f. of floor area. Minimum requirement is 2 spaces.
Off-street parking lots and garages available to the general public either without charge or on a fee basis	1 space for each 20 automobile spaces. Minimum requirement is 2 spaces. Unattended surface parking lots excepted.	Minimum of 6 spaces or 1 per 10 auto spaces. Unattended surface parking lots excepted.

**Industrial / Manufacturing**

Type of Activity	Long-term Bicycle Parking Requirement	Short-term Bicycle Parking Requirement
Manufacturing and production	1 space for each 12,000 s.f. of floor area. Minimum requirement is 2 spaces.	Number of spaces to be prescribed by the Director of City Planning. Consider minimum of 2 spaces at each public building entrance.

